



PAT300 Series

Portable Appliance Testers

User Manual

Thank you for purchasing the Megger portable appliance tester.











For your own safety and to get the maximum benefit from your instrument, please ensure that you read and understand the safety warnings and instructions before attempting to use the instrument.

These instruments are designed and manufactured by:

*Megger Limited
Archcliffe Road
Dover Kent
CT17 9EN
England*

Megger Limited reserves the right to change the specification of these instruments at any time without prior notice.

1. Contents

1.1	Unpacking the carton	4
1.2	Safety Warnings	5
1.3	Symbols used on the instrument	6
2.	Getting started	7
2.1	Carry case	7
2.2	Instrument layout	8
2.3	Controls layout	8
2.4	Instrument start-up	9
2.5	Switching off the appliance tester	9
2.6	Testing an asset	10
2.7	Remote test probe and clip	12
3.	Test options	13
3.1	110 V or 230 V selection:	13
3.2	Class I  - Assets with an earth return conductor	14
3.3	Class II  - Assets with no earth conductor	15
3.4	IEC  - Power leads fitted with 10 A IEC connector	16
3.5	Extension leads  - Single and multi-way extension leads	17
3.6	RCD 	18
3.7	Test failure	19
3.8	Changing PASS limits	19
4.	Individual tests – Quick tests:	20
4.1	Bond (Rpe) 	20
4.2	Insulation (also referred to as Riso) 	21
4.3	Leakage (Ipe) 	22
4.4	VA 	26
4.5	1.5 kV/ 3 kV  (not available on PAT310 or 320)	27
5.	SETUP	29
5.1	Test Group key configuration	29
5.2	Quick test key setup	30
5.4	Lead Null	31
6.	Battery and fuses	32
6.1	Battery function	32
6.2	Battery replacement	32
6.3	Fuse replacement	32
7.	Care and maintenance	32
8.	Specification	33
9.	Repair and Warranty	36

1.1 Unpacking the carton

Unpack the carton contents carefully. There are important documents that you should read and keep for future reference.

Please complete the pre-paid warranty card and return it to Megger Limited as soon as possible to help us reduce any delays in supporting you should the need arise.

PAT310 & 320 carton contents

- 1 PAT300 series appliance tester
- 1 Carry case
- 1 Quick-start guide
- 1 Black test lead set with probe and clip
- 1 IEC lead 0.5 m (Extension lead adaptor)
- 1 Warranty card
- 1 Owners CD manual

PAT350 Carton contents

- 1 PAT300 series appliance tester
- 1 Carry case
- 1 Quick-start guide
- 1 Black test lead set with probe and clip
- 1 IEC lead 0.5 m (Extension lead adaptor)
- 1 Warranty card
- 1 Owners CD manual
- 1 Flash test lead

1.2 Safety Warnings

The following Safety Warnings and Precautions must be read and understood before the instrument is used. They **must** be observed during use.

- For safety, only connect the PAT to a supply that is properly earthed. If in doubt, the supply should be checked by a qualified electrician.
- Do not use the instrument if there are any signs of damage.
- All test leads, probes and clips **must** be in good order, clean and with no broken or cracked insulation.
- Probes and clips should be held behind the finger guard.
- Test leads not used during a measurement should be disconnected from the Appliance tester.
- For dual voltage testers, both sockets can be live simultaneously.
- Only connect one asset to the PAT during testing.
- Tests should be carried out in the order recommended below. An appliance that fails a test should be repaired before further testing is carried out.

Recommended Sequence:

1. Earth Bond/ Continuity of the protective earth conductor (Class I devices)
2. Insulation test (or earth leakage)

In addition further tests can be performed

3. Operation test
 4. Leakage test
- Only perform an operational test after the Earth bond and insulation tests have been completed, as this test operate at mains voltage.
 - During testing, ensure no hazard will exist as a result of normal running or under fault conditions.
 - During testing the unit under test (asset) should not be touched, other than using the appropriate accessories, as faulty appliances can present a shock hazard.
 - Do not touch the exposed parts of test leads during tests as hazardous voltages may be present due to potentially faulty appliance.
 - Do not touch the IEC extension lead socket pins especially during a test, as hazardous voltages may be present due to a potentially faulty appliance
 - Assets should not be routinely flash tested. Where flash testing is required, refer to further guidance on Flash testing, section 4.5.
 - Replacement fuses **must** be of the correct rating and type. Refer to section 6.3
 - The USB connection should only be used by approved service personnel; nothing should be connected to the USB port during testing.
 - Only use NiMH rechargeable 9 V PP3 battery, do not use a non rechargeable type as this could become dangerous if charged by the instrument.
 - Serviceable fuses should only be replaced with those that are suitably rated
 - In case of an emergency use an easily accessible power point

1.3 Symbols used on the instrument



Caution: risk of electric shock



Caution: refer to accompanying notes. When displayed at the start of an insulation test, warns that a hazardous voltage may exist at the test lead probes



Equipment complies with relevant EU Directives

N13117



Equipment complies with 'C tick' requirements



FUSED



THIS EQUIPMENT SHOULD BE RECYCLED AS ELECTRONIC WASTE



HV TEST LEAD IN UNLOCKED POSITION



HV TEST LEAD IN LOCKED POSITION

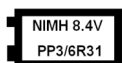

BATTERY TYPE FITTED



DO NOT CONNECT TO 230 V SUPPLY

2. Getting started

2.1 Carry case

The carry case for the appliance tester has a lead storage pouch in the lid of the case when opened. This is designed for basic lead and document storage.

Further items can be stored in the pouch. If it becomes difficult to close the case, the storage pouch can be removed from inside the case and attached to the front using the straps on the reverse of the pouch.

These are passed through the D-loops on the outside of the case and secured to the underside of the pouch using the Velcro fixings.

An additional storage pouch is available from Megger Ltd for extended storage, such that there is a pouch on both the inside and outside of the carry case.

2.2 Instrument layout

- 1 Appliance test socket 110 V
- 2 Flash test socket (PAT 350 only)
- 3 Earth bond and Insulation test probe socket
- 4 Lead null post
- 5 Firmware upgrade port
- 6 Power off (Red), Home (Grey) and Escape (Green) keys
- 7 Test keypad
- 8 Mains lead entry
- 9 Extension lead / IEC lead test return socket
- 10 Appliance test socket (230 V)
- 11 Fuse checker
- 12 Display
- 13 Display navigation
UP / DPWN / LEFT / RIGHT
OK
- 14 TEST button

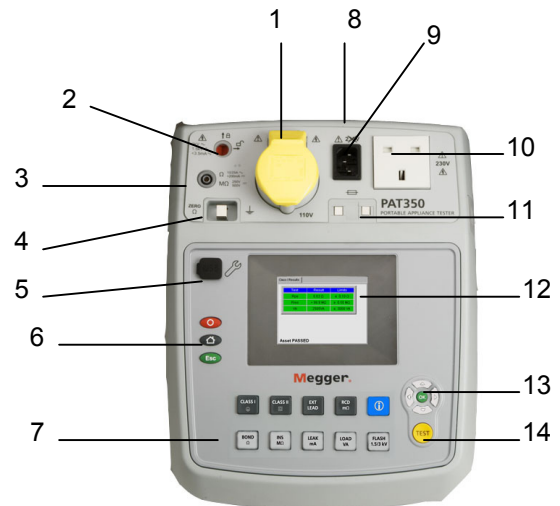

2.3 Controls layout

The following tests are available on the PAT350.

Note: The PAT310 & 320 does not include the Flash test option (j).

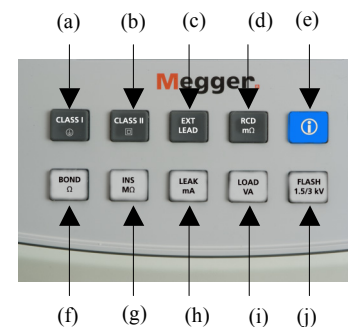

Test groups (a) to (d) – See section 3 for details		
	Test group	Description
(a)	Class I test	For testing assets with an earth return conductor
(b)	Class II test	For testing assets without an earth return conductor
(c)	IEC lead and Extension lead test	For testing extension leads and IEC type power leads (found on computers, kettles etc)
(d)	RCD tests	For testing Plug-in RCDs and extension leads fitted with RCDs.
(e)	Information	Provides technical support contact information
Individual tests (f) to (j)		
(f)	Bond test (Rpe)	Performs an earth bond/continuity test at 200 mA, 10 A or 25 A
(g)	INS test (Riso)	Performs an Insulation test at either 250 V or 500 V
(h)	Leakage test (Ipe)	Performs a RUN test and measures the power drawn
(i)	Load test (VA)	Performs an earth leakage test, either: Differential earth leakage Touch leakage Substitute leakage
(j)	Flash 1.5 kV/3 kV	Performs a flash test at the required voltage

2.4 Instrument start-up

Connect the instrument to a suitable electrical supply:

The appliance tester will automatically start when connected to the mains supply.

NOTE:

DO NOT connect any equipment to the PAT tester until it has been switched on and passed self test. Connected equipment will create a relay error and necessitate restarting the appliance tester by pressing the OFF button. Once switched off the power should be disconnected and reconnected.

The following warning screen is displayed when the PAT tester is switched on. This screen is not displayed if the PAT tester is re-started within five minutes of switching off, when the PAT tester restarts from the same screen as before.

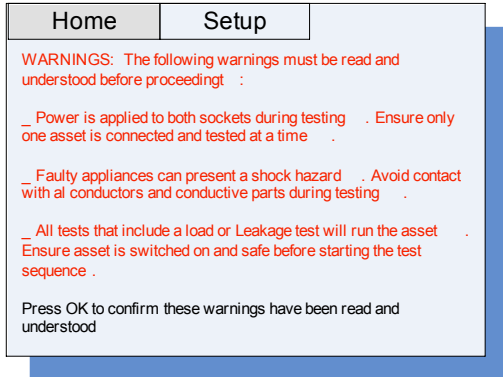

Press OK to confirm you have read and understood these warnings.

Important:

For testing **230 V electrical equipment**, connect the PAT tester to a 230 V electrical outlet.

For testing **110 V electrical equipment**, connect the PAT tester to a 110 V electrical outlet, using the optional 110 V to 230 V supply lead adaptor (not applicable to PAT310).

The instrument will display the following when all initial tests pass.

1	Home screen	All testing can be run from this screen
2	Setup options	Test limits, test duration, Language, Auto or Manual test modes etc can be changed here.
3	Power-up status and test results	Displays supply status and Self test results

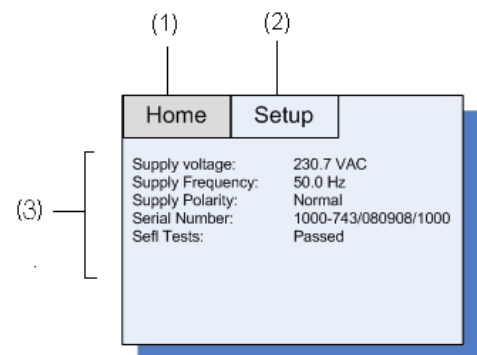

2.5 Switching off the appliance tester

To switch off the tester, press the RED off button. The display will show the message "It is now safe to remove power". Now the mains plug can be removed from the supply.

Failure to press the RED off button will discharge the FAST START battery un-necessarily as per section 2.5.1.

If the RED off button is pressed accidentally, pressing the  button will return the PAT to normal testing mode.

2.5.1 FAST Restart

If the tester is to be moved to a new location and testing continued, simply unplug the unit from the mains supply and reconnect it in the new location. The appliance tester will enter a hibernation mode during the move and restart instantly from the point power was disconnected, without any delay.

The rechargeable 9 V NIMH battery is used to maintain hibernation status whilst unplugged. This cell is continuously charged whilst the appliance tester is connected to the mains supply. Continuous use of the hibernation mode will discharge the battery. Only use the hibernation mode when a fast restart is required.

Should the move take longer than 5 minutes, the appliance tester will leave hibernation mode and complete a full power down.

2.6 Testing an asset

2.6.1 To run a test - (Example shows a Class I test in AUTOMATIC test mode)

- (a) Connect the asset to be tested to the portable appliance tester.
- (b) Press the  button for a CLASS I test for assets with a protective earth conductor.

The display will show the initial test information:

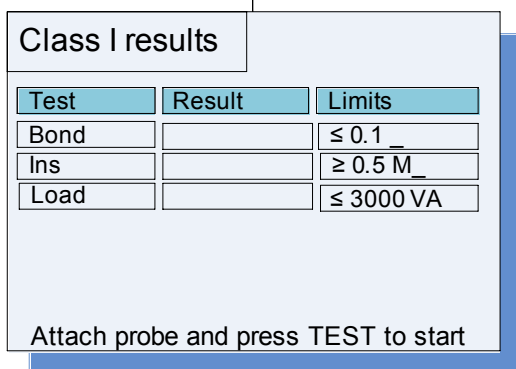

Class I results		
Test	Result	Limits
Bond		≤ 0.1 _
Ins		≥ 0.5 M_
Load		≤ 3000 VA

Attach probe and press TEST to start

- (c) Connect the bond lead to the asset and press the  button to start the test.
- (d) The Appliance tester will display any operational warnings as well as the measured values during the test and the remaining test time.

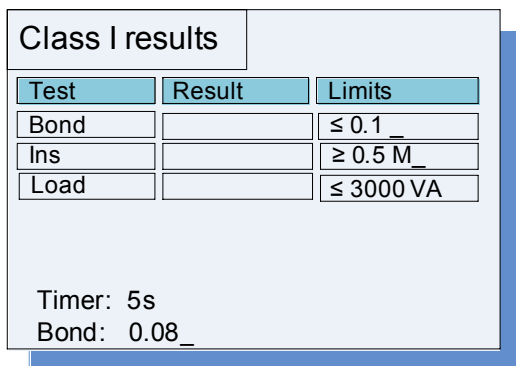

Class I results		
Test	Result	Limits
Bond		≤ 0.1 _
Ins		≥ 0.5 M_
Load		≤ 3000 VA

Timer: 5s
Bond: 0.08_

The first test will be an **Rpe** (Earth continuity / bond) test. The resistance during the test is displayed.

The Timer shows the number of seconds remaining of the test.
 After each test the worst case measurement will be displayed and tagged with a **GREEN** marker for a PASS, or a **RED** marker for a FAIL.

Note – ABORTING A TEST:

A test can be aborted at any time by pressing the  button.

Each test will run automatically unless there is a manual operation required.

Example:

Earth bond test passed

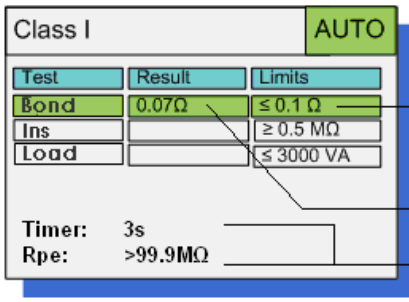

Earth bond test (Rpe) passed

Insulation test (Riso) now running

Test	Result	Limits
Bond	0.07Ω	≤ 0.1 Ω
Ins		≥ 0.5 MΩ
Load		≤ 3000 VA

Timer: 3s
Rpe: >99.9MΩ

Maximum permissible limit for Bond test

Worst case measurement during the Bond test

Automatically starts Insulation test (Riso)

Example:

Isolation (Insulation) test failed

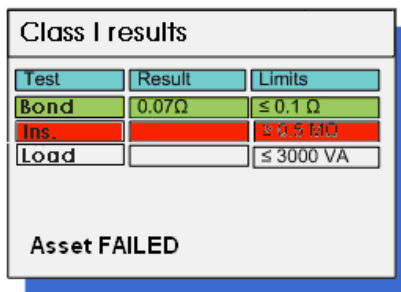

Rpe (Bond test) passed

Riso (Insulation test) failed

Further tests aborted

Test	Result	Limits
Bond	0.07Ω	≤ 0.1 Ω
Ins.		≥ 0.5 MΩ
Load		≤ 3000 VA

Asset FAILED

To return to the HOME screen or run a different type of test, press the  button

At the completion of a successful set of tests the display will show all results marked **GREEN** and the “Asset PASSED” message displayed:

Example:

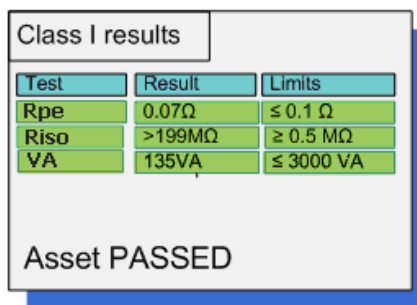



Indicates all tests have passed

Test	Result	Limits
Rpe	0.07Ω	≤ 0.1 Ω
Riso	>199MΩ	≥ 0.5 MΩ
VA	135VA	≤ 3000 VA

Asset PASSED

OPTIONS:

- (1) To return to the HOME screen press the  button.

(2) To repeat the same test (or test another CLASS I asset) press the test  button. The appliance tester will return to the first test screen and wait for the TEST  button to be pressed to commence testing.

(3) To change the test type, press the appropriate function button.

Should a test fail it will be marked with a RED tag, testing will stop and the display will show “**Asset Failed**”. Any fault should be made good before testing is re-started.

2.7 Remote test probe and clip

Some tests will require the use of the remote probe and clip. These are used where the asset under test has no earth return (Class II assets). The probe is used for both insulation and bond testing, under the control of the instrument.

Example:

Class I Insulation test (Riso)

Live and neutral are shorted together automatically in the PAT tester and a voltage (250 V or 500 V) is applied between the shorted L/N and the earth conductor as below.

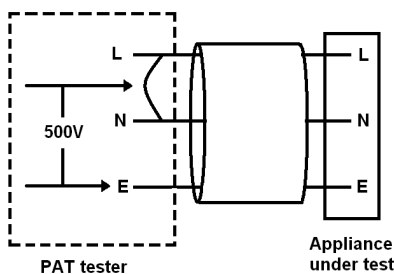

Remote probe not required

Class II Insulation test (Riso)

Live and neutral are shorted together automatically in the PAT and a voltage (250 V or 500 V) is applied between the shorted L/N and the remote probe.

The probe is connected to any metallic locations on the “Appliance Under Test” to ensure there is no breakdown of the insulation.

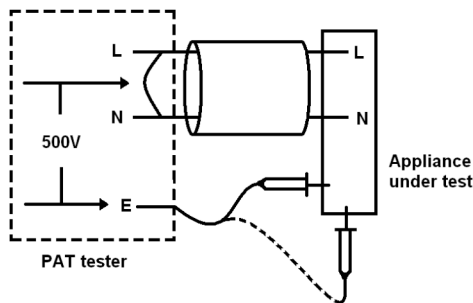

Remote probe required

3. Test options

Each test option (button) consists of a group of tests required for that class of test. The instrument will display the tests to be completed and the status of each test as they are completed, against the set Pass limit for that test. TO change PASS limits, refer to section 5 – Setup.

The following sections show the difference between automatic and manual operation, what is displayed during each test and which connections are required during the test sequence.

All tests commence from the HOME screen as below:

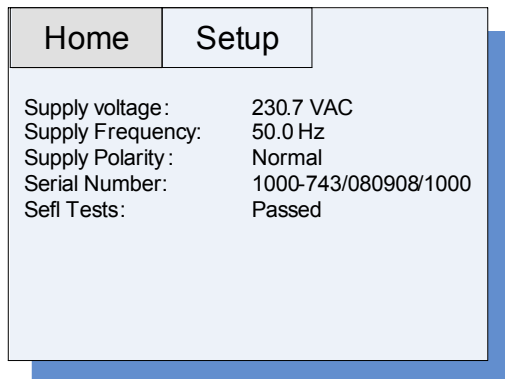

Any test can be selected or changed until the OK or TEST buttons are pressed.

On completion of the test the PAT can be returned to the home screen by pressing the  button.

Alternatively the test can be repeated by pressing the test  button **twice**. In this case the PAT will return to the first test screen of the previous test selected.

3.1 110 V or 230 V selection:

Testing 110 V ac or 230 V ac equipment is dependent on the supply voltage. Connecting the appliance tester to a 110 V ac supply automatically switches the appliance tester to the yellow 110 V test socket.

Connecting the appliance tester to a 230 V ac supply switches the tester to the 230 V test socket.

Testing examples in this document use the 230 V test socket and assume the appliance tester is connected to a 230 V ac supply.

3.2 Class I - Assets with an earth return conductor

Class I equipment depends on having an earth within the equipment and an earth return in the supply cable to provide protection should a part of the equipment become live under fault conditions.

3.2.1 Class I – automatic testing mode

AUTOMATIC		Manual action required
(1)	Bond (Rpe)	Connect remote probe to asset and press OK to continue
(2)	Insulation (Riso)	Disconnect bond probe from asset
(3)	Load (VA)	Press TEST button

Connections:



Testing sequence continued...

(2)

Test	Result	Limits
Bond	0.07_	≤ 0.1_
Ins.		≥ 0.5 M_
Load		≤ 3000 VA

Timer: 5s
Ins: >99.9M_

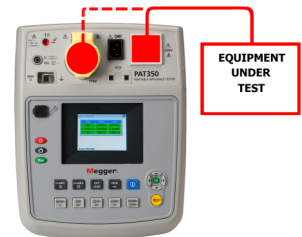

Test sequence:



Note: Disconnect remote probe.

(3)

(1) Connect remote probe to metal parts of asset

Test	Result	Limits
Bond		≤ 0.1_
Ins		≥ 0.5 M_
Load		≤ 3000 VA

Attach probe and press TEST to start

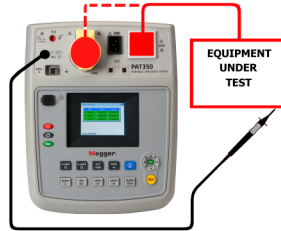

Test	Result	Limits
Bond	0.07_	≤ 0.1_
Ins.	>199M_	≥ 0.5 M_
Load		≤ 3000 VA

Asset will operate. Ensure asset is safe.
Press OK to continue

Timer: 5s



Test	Result	Limits
Bond		≤ 0.1_
Ins		≥ 0.5 M_
Load		≤ 3000 VA

Timer: 5s
Bond: 0.07_

Test	Result	Limits
Bond	0.07_	≤ 0.1_
Ins.	>199M_	≥ 0.5 M_
Load		≤ 3000 VA

Timer: 5s
Load: >195 VA

Test	Result	Limits
Bond	0.07_	≤ 0.1_
Ins.	>199M_	≥ 0.5 M_
Load	135VA	≤ 3000 VA

Asset PASSED

3.3 Class II – Assets with no earth conductor

3.3.1 Class II - automatic test mode

AUTOMATIC mode		Operator action required
(1)	Insulation (Riso)	Connect remote probe to asset and press OK to continue.
(2)	Load (VA)	Disconnect remote probe
		Press TEST button

Connection required:



Test sequence:



(1)
Connect remote probe to metal parts of asset

Class II results

Test	Result	Limits
Ins.		$\geq 0.5 \text{ M}$
Load		$\leq 3000 \text{ VA}$

Attach probe and press TEST to start

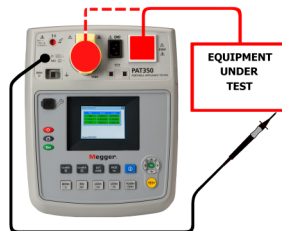

Class II results

Test	Result	Limits
Ins.		$\geq 0.5 \text{ M}$
Load		$\leq 3000 \text{ VA}$

Timer: 5s
Ins: >99.9M_

Testing sequence continued...

(2)

Class II results

Test	Result	Limits
Ins.	>199M	$\geq 0.5 \text{ M}$
Load		$\leq 3000 \text{ VA}$

Asset will operate. Ensure asset is safe.
Press OK to continue

Timer: 5s

Note: Disconnect remote probe



Class II results

Test	Result	Limits
Ins.	>199M	$\geq 0.5 \text{ M}$
Load		$\leq 3000 \text{ VA}$

Timer: 5s
Load: 135VA

Class II results

Test	Result	Limits
Ins.	>199M	$\geq 0.5 \text{ M}$
Load	135VA	$\leq 3000 \text{ VA}$

Asset PASSED

3.4 IEC - Power leads fitted with 10 A IEC connector

3.4.1 IEC lead - automatic test mode

AUTOMATIC		Operator action required
(1)	Bond (Rpe)	None
(2)	Insulation (Riso)	None
(3)	Polarity	None

Connection required:



Test sequence:

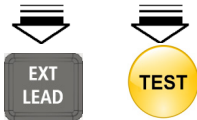

(1)

Extension (IEC) lead		
Test	Result	Limits
Bond		≤ 0.1
Ins		≥ 0.5 M
Load		≤ 3000 VA

Timer: 5s
Bond: 0.07_

(2)

Extension (IEC) lead		
Test	Result	Limits
Bond	0.07_	≤ 0.1
Ins.		≥ 0.5 M
Polarity		Pass/Fail

Timer: 5s
Ins: >99.9M_

Testing sequence continued...

(3)

Extension (IEC) Lead		
Test	Result	Limits
Bond	0.07	≤ 0.1
Ins.	>99.99M	≥ 0.5 M
Polarity		Pass/Fail

Polarity test:
Reverse polarity not permitted

Extension (IEC) Lead		
Test	Result	Limits
Rpe	0.07	≤ 0.1
Riso	>199M	≥ 0.5 M
Polarity	Normal	Normal/Rev

Asset PASSED

3.5 Extension leads - Single and multi-way extension leads

3.5.1 Extension leads – automatic mode

AUTOMATIC		Manual action required
(1)	Bond (Rpe)	None
(2)	Insulation (Riso)	None
(3)	Polarity	None

Connection required:

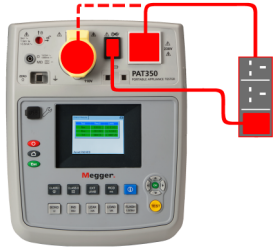

Test sequence:

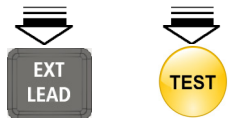

(1)

Extension (IEC) lead		
Test	Result	Limits
Bond		≤ 0.1
Ins		≥ 0.5 M
Load		≤ 3000 VA

Timer: 5s
Bond: 0.07_

(2)

Extension (IEC) Lead		
Test	Result	Limits
Bond	0.07_	≤ 0.1
Ins.		≥ 0.5 M
Polarity		Pass/Fail

Timer: 5s
Ins: >99.9M_

Testing sequence continued...

(3)

Extension (IEC) Lead		
Test	Result	Limits
Bond	0.07	≤ 0.1
Ins.	>99.99M	≥ 0.5 M
Polarity		Pass/Fail

Polarity test:
Reverse polarity not permitted

Extension (IEC) Lead		
Test	Result	Limits
Rpe	0.07	≤ 0.1
Riso	>199M	≥ 0.5 M
Polarity	Normal	Normal/Rev

Asset PASSED

Note: Test sequence can be repeated on the remaining sockets to ensure all outlets are compliant.



3.6 RCD

3.6.1 Testing portable residual current devices (RCDs) – Manual only

As there is a need to reset the RCD during the test sequence there is no fully automated test sequence, no AUTO mode exists. All testing is completed in manual mode.

AUTOMATIC		Manual action required
(1)	Test button function	Set RCD on
(2)		Press test button on RCD
(3)	½ x 30 mA	Reset RCD
	1 x 30 mA (0°)	None
(4)	1 x 30 mA (180°)	Reset RCD after trip
(5)	5 x 30 mA (0°)	Reset RCD after trip
(6)	5 x 30 mA (180°)	None

Connection required:



Test sequence:

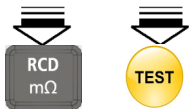

Plug in the RCD to the 230 V appliance test socket

Connect the RCD to the IEC socket using the red 0.5 m IEC test lead.

(1)

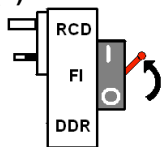

(2)

Test	Result	Limits
Test button	Pass	Pass/Fail
0.5 x I	>2000ms	>2000ms
1 x I	21.3ms	<300ms
5 x I	7.6ms	<40ms

Press the MANUAL TEST BUTTON on the RCD. Does RCD trip?

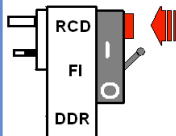

Testing sequence continued...

(3)

Test	Result	Limits
Test button	Pass	Pass/Fail
0.5 x I	>2000ms	>2000ms
1 x I	<300ms	<300ms
5 x I	<40ms	<40ms

Reset the RCD and Press OK.
Timer: 1

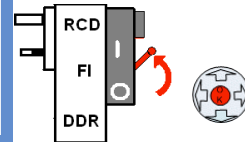

Test	Result	Limits
Test button	Pass	Pass/Fail
0.5 x I	>2000ms	>2000ms
1 x I	<300ms	<300ms
5 x I	<40ms	<40ms

1 x I at 0° trip test: 22ms
Please reset the RCD and press OK

(4)

Test	Result	Limits
Test button	Pass	Pass/Fail
0.5 x I	>2000ms	>2000ms
1 x I	<300ms	<300ms
5 x I	<40ms	<40ms

1 x I at 180° trip test: 20ms
Please reset the RCD and press OK

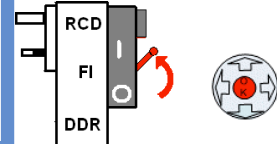

(5)

Test	Result	Limits
Test button	Pass	Pass/Fail
0.5 x I	>2000ms	>2000ms
1 x I	22ms	<300ms
5 x I	7ms	<40ms

5 x I at 0° trip test: 7ms
Please reset the RCD and press OK

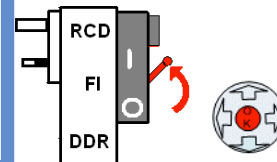

(6)

Test	Result	Limits
Test button	Pass	Pass/Fail
0.5 x I	>2000ms	>2000ms
1 x I	21.3ms	<300ms
5 x I	9ms	<40ms

Asset PASSED

3.7 Test failure

3.7.1 Test failure - automatic test mode

Should any test fail during the test sequence, the PAT will abort further testing and display a test failure screen as below:

Class I results		
Test	Result	Limits
Visual	PASS	Pass/Fail
Bond	0.35	≤ 0.1
Ins.		≥ 0.5 M
Load		≤ 3000 VA

Asset FAILED

The failed test will be tagged with a RED marker and the failed result will be recorded in the appropriate column.

No further testing should be attempted until the fault is rectified. However individual tests can be run for diagnostic purposes. However some tests may be hazardous depending on the failure mode of the asset and should only be undertaken after a risk assessment of the failed asset.

3.8 Changing PASS limits

See section 5 - SETUP

3.9 Changing test duration

See section 5 - SETUP

4. Individual tests – Quick tests:

These tests are individual tests and perform a single type of test. Where several options exist under the one function (such as Bond with 25 A, 10 A or 200 mA) then those options will be available for selection.







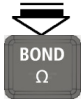
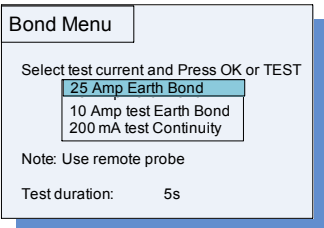

Notes:

There is no automatic mode for these tests.

Pass fail limits are not enabled. Actual measurement values are displayed during and at the completion of testing.

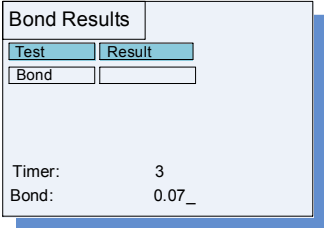
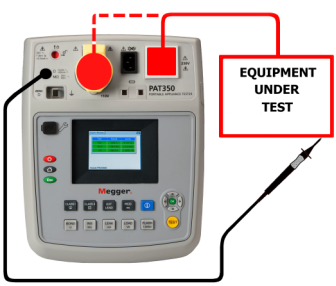
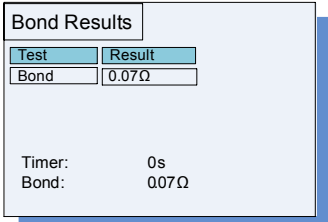
4.1 Bond (Rpe)











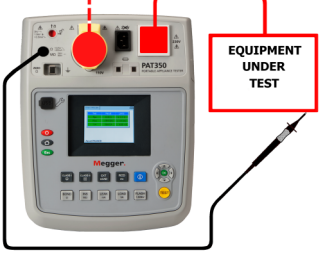

MANUAL ONLY	Manual action required	
Bond (Rpe)	Select the Bond test current Press OK to accept	
<p>Test sequence:</p>   <p>Select the test current using the up/down arrows</p> <p>Note: For PAT310, only 200 mA test is available.</p>  <p>When ready press:</p>   <p>or to continue</p> 	<p>Connection required:</p> 	<p>Continued...</p>  <p>Press  to navigate back to HOME screen or</p> <p>Press  to return to the INS selection screen or</p> <p>Press  to retest</p> <p>NOTE:</p> <p>To abort a test, press the  button.</p>

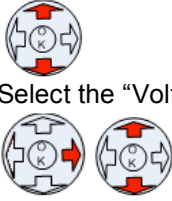
4.2 Insulation (also referred to as Riso)

INS
MΩ

4.2.1 Running an Insulation (Isolation) test

This test will apply a 250 V or 500 V (default) test voltage between the live/neutral pair and earth conductor. During this test the live and neutral are shorted together by the PAT tester for the duration of the test.

MANUAL ONLY	Manual action required																				
<p>Insulation (Riso)</p>	<p>Select insulation test voltage Select class of test Press OK to accept</p>																				
<p>Connection required:</p> <div style="display: flex; justify-content: space-around;"> <div style="text-align: center;"> <p>Class I equipment</p>  </div> <div style="text-align: center;"> <p>Class II equipment</p>  </div> </div> <p>Test sequence:</p>  <div style="border: 1px solid black; padding: 5px; margin-top: 10px;"> <p>Insulation Menu</p> <p>Select voltage and Press OK or TEST</p> <table border="1"> <tr> <td>Class I 500V ></td> <td>230V Appliance</td> </tr> <tr> <td>Class II 500V ></td> <td>110V Appliance</td> </tr> <tr> <td>Class I 250V ></td> <td></td> </tr> <tr> <td>Class II 250V ></td> <td></td> </tr> </table> <p>Note: For Class II use the remote probe</p> <p>Test Duration: 4 seconds</p> </div> <p>Select the "Class type" and "Test voltage"</p> <p>Note: 110 V Appliance options are not available on the PAT310</p>  <p>Select the "Voltage rating"</p> <p>When ready, press:</p>  or 	Class I 500V >	230V Appliance	Class II 500V >	110V Appliance	Class I 250V >		Class II 250V >		<p>Continued...</p> <div style="border: 1px solid gray; padding: 5px; margin-bottom: 10px;"> <p>Insulation results (230V test socket)</p> <table border="1"> <thead> <tr> <th>Class I Test</th> <th>Result</th> </tr> </thead> <tbody> <tr> <td>Ins 500V</td> <td></td> </tr> </tbody> </table> <p>Please ensure appliance is switched on . Press OK to continue, TEST to abort</p> </div> <div style="display: flex; justify-content: space-around; align-items: center;">  to continue or  to abort </div> <div style="border: 1px solid gray; padding: 5px; margin-bottom: 10px;"> <p>Insulation results (230V test socket)</p> <table border="1"> <thead> <tr> <th>Class I test</th> <th>Result</th> </tr> </thead> <tbody> <tr> <td>Ins 500V</td> <td></td> </tr> </tbody> </table> <p>Timer: 3 Riso: >199M_</p> </div> <div style="border: 1px solid gray; padding: 5px;"> <p>Insulation results (230V test socket)</p> <table border="1"> <thead> <tr> <th>Test</th> <th>Result</th> </tr> </thead> <tbody> <tr> <td>Ins 500V</td> <td>>99.99M_</td> </tr> </tbody> </table> <p>Timer: 0s Ins: >99.99M_</p> </div> <p>Press  to navigate back to HOME screen or Press  to return to the Insulation selection screen or Press  to retest</p> <p>NOTE: To abort a test, press the  button.</p>	Class I Test	Result	Ins 500V		Class I test	Result	Ins 500V		Test	Result	Ins 500V	>99.99M_
Class I 500V >	230V Appliance																				
Class II 500V >	110V Appliance																				
Class I 250V >																					
Class II 250V >																					
Class I Test	Result																				
Ins 500V																					
Class I test	Result																				
Ins 500V																					
Test	Result																				
Ins 500V	>99.99M_																				



4.3 Leakage (Ipe)

The Leakage test provides three different methods for measuring leakage current of equipment:

Differential leakage test: (section 4.3.1)

This measures the difference in current between the live and neutral conductors. The difference is displayed as the leakage current. The test socket will be automatically chosen depending on the supply voltage. The measured value is adjusted to reflect the worst leakage current at the upper operating voltage limit.

Touch leakage: (section 4.3.2)







Where no earth return path exists, (Class II) one has to be provided to simulate the equipment being held in the hand. The test socket will be automatically chosen depending on the supply voltage. The measured value is adjusted to reflect the worst leakage current at the upper operating voltage limit.

Substitute leakage: (section 4.3.3)

This measures the leakage current in the earth conductor using a low AC voltage (typically 40 Vac). This reduces the risk of electric shock and prevents the equipment from running during the test, where this would otherwise be considered dangerous. The test socket is optional since this test is independent of the supply voltage. The measured value is adjusted to reflect the worst leakage current at the upper operating voltage limit.

IMPORTANT: The equipment must be running in its normal operating mode for the test, i.e. a hair dryer must be set to its hottest setting and have its trigger depressed.

4.3.1 Ipe Differential

MANUAL ONLY	Manual action required										
Leakage - Differential	Select the differential test voltage Select classification of test type Press OK to accept										
<p>Connection required:</p>  <p>Test sequence:</p>  <p>(1)</p> <div data-bbox="152 1558 553 1835" style="border: 1px solid black; padding: 5px;"> <p>Leakage Menu</p> <p>Select voltage and Press OK or TEST</p> <table border="1"> <tr> <td>Differential leakage ></td> <td>Class I 230V</td> </tr> <tr> <td>Touch current (230v)</td> <td>Class II 230V</td> </tr> <tr> <td>Substitute leakage ></td> <td></td> </tr> </table> <p style="color: red;">Asset will operate. Ensure asset is switched on and safe.</p> <p>Note: For Class II appliances, use the remote probe</p> <p>Test duration: 5 seconds</p> </div> <p>Select the test type using the up/down arrows</p>	Differential leakage >	Class I 230V	Touch current (230v)	Class II 230V	Substitute leakage >		<p>Continued...</p>  <p>Select the class of test using right arrow then up/down arrows</p>  <p>When ready press:</p>  or  <p>(2)</p> <div data-bbox="824 1558 1230 1835" style="border: 1px solid black; padding: 5px;"> <p>Leakage results (230V test socket)</p> <table border="1"> <tr> <td>Class I test</td> <td>Result</td> </tr> <tr> <td>Leakage (Diff)</td> <td></td> </tr> </table> <p>Please ensure appliance is switched on . Press OK to continue, TEST to abort</p> </div> <p>(This is displayed if the PAT does not detect an asset connected to the test socket or the asset is open circuit)</p>	Class I test	Result	Leakage (Diff)	
Differential leakage >	Class I 230V										
Touch current (230v)	Class II 230V										
Substitute leakage >											
Class I test	Result										
Leakage (Diff)											

Continued...



to continue or





to abort

(3)

Leakage results (230V test socket)	
Class I test	Result
Leakage (Diff)	
Timer:	3s
Ipe:	0.15mA

Leakage results (230V test socket)	
Class I test	Result
Leakage (Diff)	0.15mA
Timer:	0s
Ipe:	0.15mA

Press  to navigate back to HOME screen or

Press  to return to the Leakage Menu selection screen or

Press  to retest









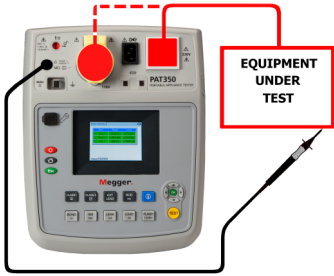

NOTE:

To abort DURING a test, press the  button.

4.3.2 Touch Leakage – Itouch



















Test sequence is the same as Ipe – differential, except the earth leakage connection must be made using the remote probe to simulate contact by the operator.

MANUAL ONLY	Manual action required												
<p>Touch leakage (Itouch)</p>	<p>Press OK to accept Connect remote test probe</p>												
<p>Connection required:</p>  <p>Test sequence:</p>  <p>Select the test type using the UP/Down arrows</p>  <p>(1)</p> <div data-bbox="154 1060 560 1354" style="border: 1px solid black; padding: 5px;"> <p>Leakage Menu</p> <p>Select voltage and Press OK or TEST</p> <p>Differential leakage > Touch current (230V) Substitute leakage ></p> <p style="color: red;">Asset will operate. Ensure asset is switched on and .safe</p> <p>Note: For Class II appliances, use the remote probe</p> <p>Test duration: 5 seconds</p> </div> <p>When ready press:</p>  or  <p>(2)</p> <div data-bbox="154 1606 560 1900" style="border: 1px solid black; padding: 5px;"> <p>Leakage results (230V test socket)</p> <table border="1" style="width: 100%;"> <tr> <td>Class II test</td> <td>Result</td> </tr> <tr> <td>Leakage (Touch)</td> <td></td> </tr> </table> <p>Please ensure appliance is switched on . Press OK to continue, TEST to abort.</p> </div>	Class II test	Result	Leakage (Touch)		<p>Continued...</p> <p>This is displayed if the PAT does not detect an Asset connected to the test socket or the asset is open circuit.</p> <p>When ready press:</p>  to continue or  to abort <p>(3)</p> <div data-bbox="828 787 1242 1081" style="border: 1px solid black; padding: 5px;"> <p>Leakage results (230V test socket)</p> <table border="1" style="width: 100%;"> <tr> <td>Class II test</td> <td>Result</td> </tr> <tr> <td>Leakage (Touch)</td> <td></td> </tr> </table> <p>Timer: 3s Ipe: 0.15mA</p> </div> <div data-bbox="828 1102 1242 1396" style="border: 1px solid black; padding: 5px;"> <p>Leakage results (230V test socket)</p> <table border="1" style="width: 100%;"> <tr> <td>Class II test</td> <td>Result</td> </tr> <tr> <td>Leakage (Touch)</td> <td>0.15mA</td> </tr> </table> <p>Timer: 0s Ipe: 0.15mA</p> </div> <p>Press  to navigate back to HOME screen or Press  to return to the Leakage Menu selection screen or Press  to retest</p> <p>NOTE:</p> <p>To abort DURING a test press the  button.</p>	Class II test	Result	Leakage (Touch)		Class II test	Result	Leakage (Touch)	0.15mA
Class II test	Result												
Leakage (Touch)													
Class II test	Result												
Leakage (Touch)													
Class II test	Result												
Leakage (Touch)	0.15mA												

4.3.3 Ipe – Substitute leakage













MANUAL ONLY	Manual action required																				
<p>Ipe - Substitute</p>	<p>Select the test socket Select classification of test type Press OK to accept</p>																				
<p>Connection required: Class I assets</p>  <p>Class II assets</p>  <p>Test sequence:</p>   <p>Select the test type using the up/down arrows</p>  <p>(1)</p> <div data-bbox="152 1150 553 1430" style="border: 1px solid black; padding: 5px;"> <p>Leakage Menu</p> <p>Select voltage and Press OK or TEST</p> <table border="1"> <tr> <td>Differential leakage ></td> <td>Class I 230V</td> </tr> <tr> <td>Touch current (230v)</td> <td>Class I 110V</td> </tr> <tr> <td style="background-color: #e0e0e0;">Substitute leakage ></td> <td>Class II 230V</td> </tr> <tr> <td></td> <td>Class II 110V</td> </tr> </table> <p style="color: red;">Asset will operate. Ensure asset is switched on and .safe</p> <p>Note: For Class II appliances, use the remote probe</p> <p>Test duration: 5 seconds</p> </div> <p>Select the class of test using right arrow then up/down arrows NOTE: 110 V not available on PAT310</p>   <p>When ready press:</p>  <p>or</p> 	Differential leakage >	Class I 230V	Touch current (230v)	Class I 110V	Substitute leakage >	Class II 230V		Class II 110V	<p>Continued... (2)</p> <div data-bbox="824 457 1230 737" style="border: 1px solid black; padding: 5px;"> <p>Leakage results (230V test socket)</p> <table border="1"> <tr> <td>Class I test</td> <td>Result</td> </tr> <tr> <td>Leakage (Sub)</td> <td></td> </tr> </table> <p>Please ensure appliance is switched on . Press OK to continue, TEST to abort</p> </div> <p>This is displayed if the PAT does not detect an asset connected to the test socket, or the asset is open circuit.</p>   <p>to continue or</p>   <p>to abort</p> <p>(3)</p> <div data-bbox="824 1031 1230 1310" style="border: 1px solid black; padding: 5px;"> <p>Leakage results (230V test socket)</p> <table border="1"> <tr> <td>Class I test</td> <td>Result</td> </tr> <tr> <td>Leakage (Sub)</td> <td></td> </tr> </table> <p>Timer: 3s Ipe: 0.15mA</p> </div> <div data-bbox="824 1339 1230 1619" style="border: 1px solid black; padding: 5px;"> <p>Leakage results (230V test socket)</p> <table border="1"> <tr> <td>Class I test</td> <td>Result</td> </tr> <tr> <td>Leakage (Sub)</td> <td>0.15mA</td> </tr> </table> <p>Timer: 0s Ipe: 0.15mA</p> </div> <p>Press  to navigate back to HOME screen or Press  to return to the Riso selection screen or Press  to retest</p> <p>NOTE: To abort DURING a test press the  button.</p>	Class I test	Result	Leakage (Sub)		Class I test	Result	Leakage (Sub)		Class I test	Result	Leakage (Sub)	0.15mA
Differential leakage >	Class I 230V																				
Touch current (230v)	Class I 110V																				
Substitute leakage >	Class II 230V																				
	Class II 110V																				
Class I test	Result																				
Leakage (Sub)																					
Class I test	Result																				
Leakage (Sub)																					
Class I test	Result																				
Leakage (Sub)	0.15mA																				

4.4 VA

This test measures the power consumption of the equipment when running. The results are displayed in VA.

IMPORTANT: The equipment must be running in its normal operating mode for the test, i.e. a hair dryer must be set to its hottest setting and have its trigger depressed.

MANUAL ONLY	Manual action required																		
<p>Load (VA)</p>	<p>Press OK to accept</p>																		
<p>Connection required:</p>  <p>Test sequence:</p> <p></p> <p>(1)</p> <div style="border: 1px solid #ccc; padding: 5px; background-color: #e0e0e0;"> <p style="text-align: center; color: red;">Asset will operate. Ensure asset is switched on and safe.</p> <p>Press OK or TEST to continue.</p> <p>Test Duration: 5s</p> </div> <p>When ready press:</p> <p> or </p> <p>(2)</p> <div style="border: 1px solid #ccc; padding: 5px; background-color: #e0e0e0;"> <table border="1" style="width: 100%; border-collapse: collapse;"> <tr><td colspan="2">Load test</td></tr> <tr><td>Class II test</td><td>Result</td></tr> <tr><td>Load</td><td></td></tr> </table> <p style="font-size: small;">Please ensure appliance is switched on. Press OK to continue, TEST to abort.</p> </div>	Load test		Class II test	Result	Load		<p>Continued...</p> <p>When ready press:</p> <p> to continue or  to abort</p> <p>(3)</p> <div style="border: 1px solid #ccc; padding: 5px; background-color: #e0e0e0;"> <table border="1" style="width: 100%; border-collapse: collapse;"> <tr><td colspan="2">Load test</td></tr> <tr><td>Test</td><td>Result</td></tr> <tr><td>Load</td><td></td></tr> </table> <p>Timer: 3s Load: 356VA</p> </div> <div style="border: 1px solid #ccc; padding: 5px; background-color: #e0e0e0;"> <table border="1" style="width: 100%; border-collapse: collapse;"> <tr><td colspan="2">Load test</td></tr> <tr><td>Test</td><td>Result</td></tr> <tr><td>Load</td><td>356VA</td></tr> </table> <p>Timer: 3s Load: 356VA</p> </div> <p>Press  to navigate back to HOME screen or Press  to return to the VA initial screen Press  to retest appliance</p> <p>NOTE:</p> <p>To abort a test press the  button.</p>	Load test		Test	Result	Load		Load test		Test	Result	Load	356VA
Load test																			
Class II test	Result																		
Load																			
Load test																			
Test	Result																		
Load																			
Load test																			
Test	Result																		
Load	356VA																		

4.5 1.5 kV/ 3kV (not available on PAT310 or 320)

Warning: The flash test should not be used for general “In-service” testing. It should only be used when instruments have been repaired.

The flash test provides a high AC test voltage (1500 V or 3000 V) and measures the leakage current. This can be a destructive test and is usually only used on equipment that has been repaired. It is not generally used for “IN-service testing” of electrical equipment.

MANUAL ONLY	Manual action required
Flash	Select Flash test voltage Press OK to accept Hold down TEST key to apply Flash test voltage

Connection required:

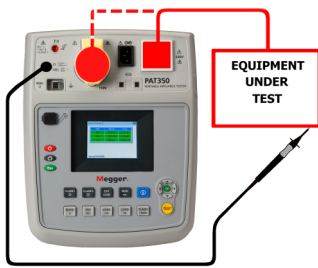

Test sequence:

Flash lead connection:

The flash test lead should be inserted fully and turned so the arrows align with the lock symbol before testing.

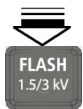
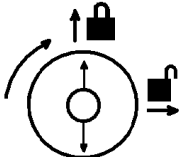

(1)

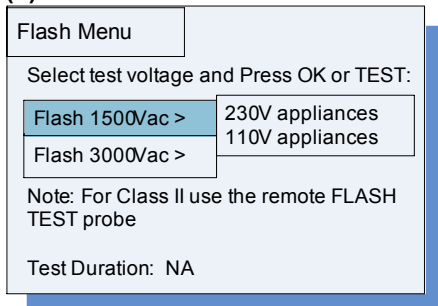

Select the test voltage using the up/down arrows



Continued...

Select the class of test using right arrow



then up/down arrows



Press  to select

(2)

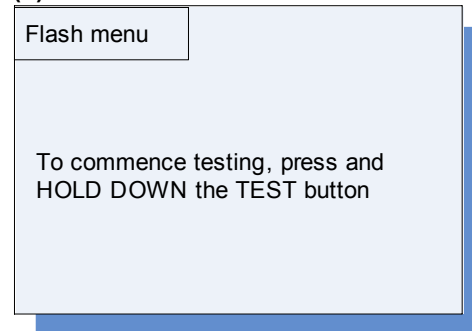

When ready press and **HOLD DOWN** the TEST button



The test will only run while the  button is depressed.

(3)

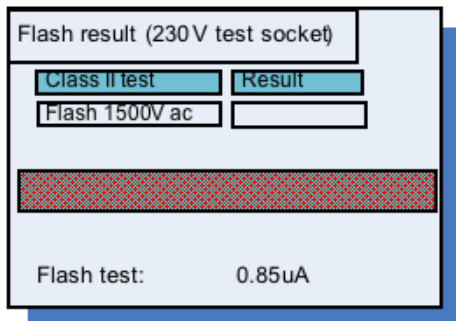

Release the button to abort the test.

(4)

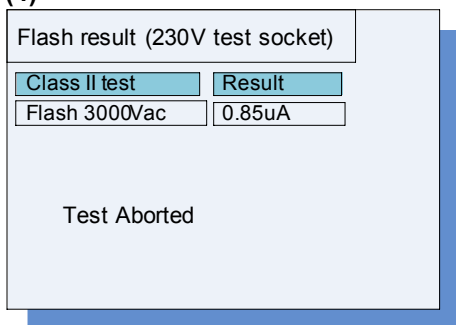

Press  to navigate back to HOME screen or

Press  to return to the Riso selection screen or

Press  to retest

Disconnecting the flash probe lead

To release the flash test probe, turn the arrow on the probe connector to the unlock symbol before attempting to extract the connector.

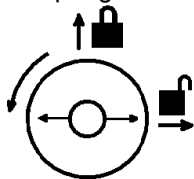

Note:

The flash test is only available on the PAT350. The following message is displayed on the PAT310 or 320 if the flash test function is selected:

“This function is not available on this model” www.megger.com

5. SETUP

5.1 Test Group key configuration

Allows changes the test parameters of the individual test groups Class I, Class II, IEC and RCD tests.

(1)

Home	Setup
Supply voltage:	230.7 VAC
Supply Frequency:	50.0 Hz
Supply Polarity:	Normal
Serial Number:	1000-743/080908/1000
Self Tests:	Passed

Press  to select setup

Press  to select "Test Group"

(2)



Home	Setup
Test group keys	Class I
Quick test keys	Class II
Lead null	Ext Lead
	RCD

Press  to select Test Group

Press  to accept selection.

(3)

Class I Setup	
Ins. Test time	5s
Ins Pass limit	20M
Ins Test type:	Class I 500V
Bond Test time:	5s
Bond Pass limit	0.1
Bond Test type:	25A Earth bond
Load Test time:	10s
Load rating	3000VA

Press  followed by  to change test limits

Continued...



(4)

Class I Setup	
Ins. Test time	5s
Ins Pass limit	1s
Ins Test type:	2s
Bond Test time:	3s
Bond Pass limit	4s
Bond Test type:	5s
Load Test time:	10s
Load rating	20s

Press  to accept.

To return to Main test screen press 

Alternatively press  first to select a different test

then  and  to change the test limits, test time or test type, for example selecting RCD:

(5)

RCD Setup	
RCD Test type	Full sequence
	Full sequence
	30mA Test

Press  to accept.

To repeat process for Test times, pass limits etc

To return to Setup menu press 

To return to Main test screen press 

5.2 Quick test key setup

Changes the test parameters of the individual test groups Riso, Rpe lpe and Flash test.
 Note: The Flash test function is only available on the PAT350 models.

(1)

Home	Setup	AUTO
Supply voltage:	230 Vac	
Supply frequency:	50Hz	
Polarity:	Passed	
Self Test:	Passed	
Battery:	OK	
Select a test...		

Press  to select "Setup"

(2)

Home	Setup	
Test group keys	Class I	
Quick test keys	Class II	
Lead null	Ext Lead	
	RCD	

Press  to select "Quick test keys"

(3)



Home	Setup	
Test group keys >		
Quick test keys		
Lead null		

Press  to select Quick Test

(4)

Quick test config	
Ins. test time:	5s ▼
Bond test time:	5s ▼
Load test time:	5s ▼
Leakage test time:	5s ▼

Continued...



Press  followed by  to change test times

(5)

Quick test config	
Ins. test time:	5s ▼
Bond test time:	2s
Load test time:	4s
Leakage test time:	10s
	20
	Infinite

Press  to accept

To return to Main test screen press 

Alternatively press  first to select a different test then  to change the test time or test limits.

Press  to accept

To return to Main test screen press 

5.4 Lead Null

Allows the compensation for additional lead resistance when performing Bond and continuity measurements.

Lead null will remove test lead resistance up to 9.99 Ω . Setting a null value greater than 9.99 Ω will generate the warning message:

“Lead NULL > 9.99 Ω Null not set”

(1)

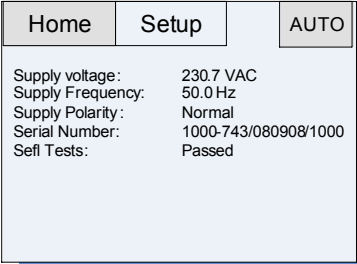

Press  to select setup

Press  to select “Lead Null”

(2)

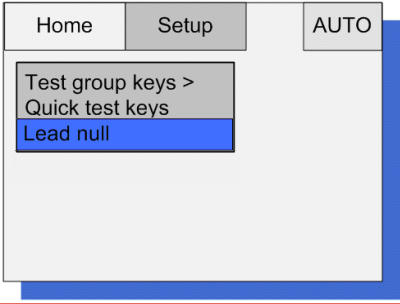

Press  to enter “Lead Null”

(3)

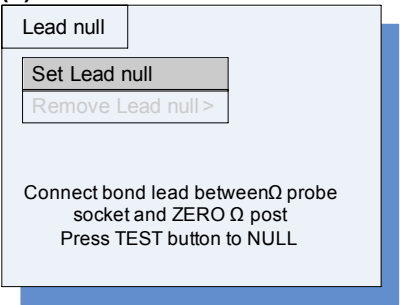

Connect Bond lead as instructed and press  to set Null

Continued...

(4)

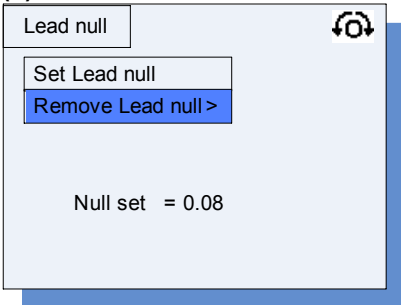

Press  to return to initial screen

To remove Lead Null select “Remove Lead Null”.

Open circuit the Bond test lead and press 

(5)

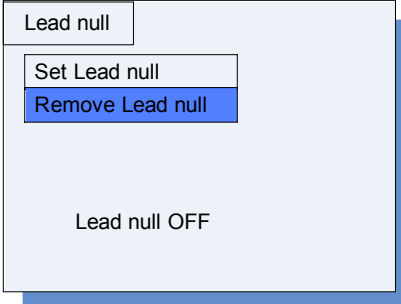

6. Battery and fuses

6.1 Battery function

The PAT300 series are mains powered instruments. However a 9 V PP3 rechargeable NiMH battery is fitted to allow fast restart should the PAT be unplugged and reconnected to an electrical supply in less than 5 minutes.

The PAT tester will operate with a discharged battery or no battery fitted, but will perform a full power-up sequence when re-connected to a supply.

The battery is continually charged whilst the Appliance tester is operating. Only fit NiMH rechargeable batteries.

Low battery is indicated by the battery warning in the main screen.

Warning: Do not switch on the instrument or connect test leads with the battery cover removed. Only use NiMH rechargeable battery, other types may cause battery explosion.

6.2 Battery replacement

Warning: Do not switch the instrument on with the battery cover removed or test leads connected.

1. Disconnect any test leads from the instrument.
2. Switch off the instrument and disconnect (the instrument) from any electrical circuits.
3. Remove the battery cover with a small crosshead screwdriver.
4. Remove the old battery and refit a new one, observing the terminal polarity.
5. Replace the cover and retaining screw.

Note: Battery cells should not be left in an instrument which may remain unused for an extended period.

Warning: Only use NiMH rechargeable cells. It is dangerous to fit alkaline cells which could explode or catch fire.

6.3 Fuse replacement

Warning: Do not switch the instrument on with the fuse cover removed or test leads connected.

1. Disconnect any test leads from the instrument.
2. Switch off the instrument and disconnect (the instrument) from any electrical circuits.
3. Remove the fuse cover with a small crosshead screwdriver.
4. Replace the blown fuse with the correct type and rating, e.g. 5 x 20 mm 250 V, 100 mA, 1.5 kA high breaking capacity (HBC) type.
5. Replace the fuse cover

7. Care and maintenance

The PAT300 series instruments require very little maintenance. Instrument and test leads should be checked before use to ensure there is no damage.

When necessary, the instrument can be cleaned with a damp cloth or Isopropyl alcohol.

8. Specification

All quoted accuracies are stated at +20 °C.

Power Supply: 110 V $\pm 10\%$ ± 1 V 50 Hz $\pm 1\%$ ± 0.1 Hz 60 Hz
230 V $\pm 10\%$ ± 1 V 50 Hz $\pm 1\%$ ± 0.1 Hz

Internal battery: 1 x 9V type NiMH rechargeable cell (PP3, MN1604, 6F22, 6LR61, U9LV-J).
Battery types need to be checked e.g. PP3 type is an old zinc carbon not NiMH

DO NOT USE NON-RECHARGEABLE (Alkaline) CELLS - Risk of explosion.

Accuracy (at 20 °C)

Supply

Voltage measurement: $\pm 2\% \pm 1$ V
Frequency measurement: $\pm 1\% \pm 0.1$ Hz

Bond test

Open circuit test voltage: 9 V ac $\pm 10\%$ ± 0.1 V (supply :230 V 50Hz)
10 A Bond test current: 10 A rms $\pm 20\%$ ± 0.5 A into 0.1 Ω
26 A Bond test current: 26 A rms $\pm 5\%$ ± 0.5 A into 0.1 Ω
Earth Bond resistance accuracy: $\pm 5\% \pm 3$ digits (0 to 0.5 Ω)
 $\pm 5\% \pm 5$ digits (0.5 to 1.99 Ω)
Earth bond resistance resolution: 10 m Ω (0 to 1.99 Ω)
Display range: 0 to 1.99 Ω
Bond test nulling: Up to 9.99 Ω
Adjustable test duration: User selectable from 1 sec to 60 sec + ∞

Continuity test

Continuity test compliance voltage: $> +4$ V dc $-0\%/+10\%$ open circuit
Continuity test current: ± 210 mA $\pm 10\%$
 ≥ 200 mA when measuring load 0.2 Ω to 2 Ω
Continuity resistance accuracy: $\pm 5\% \pm 3$ digits (0 to 0.99 Ω)
 $\pm 5\% \pm 5$ digits (1 to 19.99 Ω)
Continuity resistance resolution: 10 m Ω (0 to 19.99 Ω)
Display range: 0 to 19.99 Ω
Continuity test nulling: up to 9.99 Ω
Test duration: User selectable from 1 sec to 60 sec + ∞

Insulation test

Insulation test voltage: 250 V dc $-0\%/+25\%$ open circuit
500 V dc $-0\%/+25\%$ open circuit
 ≥ 500 V -10% dc across 0.5 M Ω load
Short circuit current: < 2 mA dc
Insulation resistance accuracy: $\pm 2\% \pm 3$ digits < 20 M Ω
 $\pm 5\% \pm 10$ digits > 20 M Ω
Insulation resistance resolution: 0.01 M Ω (0.10 to 99.99 M Ω)
Display Range: 0.01 M Ω to 99.99 M Ω
Test duration: User selectable from 1 sec to 20 sec + ∞

Substitute leakage test

Test voltage: 40 V ac $\pm 5\%$
Test frequency: Nominal mains 50/60 Hz
Leakage current accuracy: $\pm 5\% \pm 5$ digits
Leakage current resolution: 0.01 mA
Display range: 0 to 19.99 mA
Test duration: User selectable from 1 sec to 10 sec + ∞
Reading corrected to 230 V + 10% or 110 V + 10% ac.

Differential leakage current

Test voltage: Nominal mains 110/230 V ac
Test frequency: Nominal mains 50/60 Hz
Differential leakage current accuracy: $\pm 5\% \pm 5$ digits
Differential leakage current resolution: 0.01 mA
Display range: 0 to 19.99 mA
Test duration: User selectable from 1 sec 10 sec + ∞

Reading corrected to 230 V + 10% or 110 V + 10% ac.

Touch current test

Test voltage: Nominal mains 110/230 V ac
Test frequency: Nominal mains 50/60 Hz
Touch current accuracy: $\pm 5\% \pm 5$ digits
Touch current resolution: 0.01 mA
Display range: 0 to 10 mA
Test duration: User selectable from 1 sec to 10 sec + ∞
Reading corrected to 230 V + 10% or 115 V + 10% ac.

Operational test

Test voltage: Nominal mains 110/230 V ac
Accuracy: $\pm 5\% \pm 5$ digits (0 VA to 99 VA)
 $\pm 5\% \pm 50$ digits (100 VA to 999 VA)
 $\pm 5\% \pm 100$ digits (1000 VA to 3700 VA)
Resolution: 1 VA (0 to 3700 VA)
Display range: 0 to 3990 VA
Reading corrected to 230 V or 110 V ac. Results show load VA,
Test duration: User selectable from 1 sec to 60 sec + ∞

Extension lead test

Test includes insulation and bond tests.

Polarity test voltage: 12 V
Polarity: Lead OK
Live Neutral shorted
Live Neutral Reversed
Live/Neutral Open Circuit

Flash test

Flash test voltage: 1500 V ac nominal for Class 1
3000 V ac nominal for Class 2
Flash test current: < 3.5 mA short circuit @ 253 V primary supply voltage
Flash test breakdown current accuracy: $\pm 5\% \pm 5$ digits
Flash test breakdown current resolution: 0.01 mA
Display range: 0 to 3 mA
Test duration: For as long as the TEST button is pressed

Portable RCD test

RCD test voltage:	Nominal mains 110 V/230 V
RCD test frequency:	50 Hz
Test current accuracy:	-8% to -2% ($\frac{1}{2} \times I$) +2% to +8% (1 x I, 5 x I)
Trip time accuracy:	$\pm 1\% \pm 5$ digits
Trip time resolution:	0.1 ms
Display range:	0 to 1999 ms ($\frac{1}{2} \times I$) 0 to 300 ms (1 x I) 0 to 40 ms (5 x I)

Fuse test

Fuse test voltage:	3.3 V
Indication:	Audible buzzer for OK

Circuit test (Carried out automatically, not available to user)

Circuit test voltage:	12 V
Circuit test frequency:	Nominal Mains 50/60 Hz
Circuit test current:	< 100 mA short circuit

Dimensions:

Instrument	250 mm x 320 mm x 175 mm
Instrument + case	290 mm x 400 mm x 190 mm
Auxiliary pouch:	60 mm x 300 mm x 200 mm

Weight:**PAT310**

Instrument only:	2.5 kg
Instrument plus case:	3.0 kg

PAT320

Instrument only:	3 kg
Instrument plus case:	3.5 kg

PAT350

Instrument only:	4 kg
Instrument plus case:	4.5 kg

Fuses:

Mains plug fuse uses BS1363 13 A fuse type: 5 x 20 mm 250 V, 100 mA, 1.5 kA High Breaking Capacity (HBC) type.

Safety protection

The instruments meet EN 61010-1 (2001) to 300 V phase to earth, Category II. Also refer to safety warnings supplied.

E.M.C.

In accordance with IEC 61326:2006 including amendment No.1.

Operating temperature:	-10 °C to +50 °C
Storage temperature:	-20 °C to +60 °C
Humidity:	90% RH @ -10 °C +30 °C 75% RH @ +30 °C to +50 °C
Supply Voltage:	99 V to 253 V @ 50 Hz
Free fall:	0.25 m
Bump test:	6 x 1000 bumps at 40 g
Push button switch life:	>50,000 operations
Maximum altitude:	2,000 m to full safety spec.
Dust and water:	IP40

9. Repair and Warranty

The instrument contains static sensitive devices, and care must be taken in handling the printed circuit board. If an instrument's protection has been impaired it should not be used, but sent for repair by suitably trained and qualified personnel. The protection is likely to be impaired if for example, it shows visible damage, fails to perform the intended measurements, has been subjected to prolonged storage under unfavourable conditions, or has been subjected to severe transport stresses.

NEW INSTRUMENTS ARE GUARANTEED FOR 1 YEAR FROM THE DATE OF PURCHASE BY THE USER.

Note: Any unauthorized prior repair or adjustment will automatically invalidate the Warranty.

CALIBRATION, REPAIR AND SPARE PARTS

For service requirements for Megger Instruments contact:

Megger Limited or	Megger
Archcliffe Road	Valley Forge Corporate Centre
Dover	2621 Van Buren Avenue
Kent CT17 9EN	Norristown PA 19403
England.	U.S.A.
Tel: +44 (0) 1304 502 243	Tel: +1 610 676 8579
Fax: +44 (0) 1304 207 342	Fax: +1 610 676 8625

Megger operate fully traceable calibration and repair facilities, ensuring your instrument continues to provide the high standard of performance and workmanship you expect. These facilities are complemented by a worldwide network of approved repair and calibration companies to offer excellent in-service care for your Megger products.

Returning your product to Megger - UK and USA service centres

1. When an instrument requires recalibration, or in the event of a repair being necessary, a Returns Authorisation (RA) number must first be obtained from one of the addresses shown above. You will be asked to provide the following information to enable the Service Department to prepare in advance for receipt of your instrument, and to provide the best possible service to you.
 - Model, e.g. PAT300.
 - Serial number, to be found on the underside of the case or on the calibration certificate.
 - Reason for return, e.g. calibration required, or repair.
 - Details of the fault if the instrument is to be repaired.
2. Make a note of the RA number. A returns label can be emailed or faxed to you if you wish.
3. Pack the instrument carefully to prevent damage in transit.
4. Ensure the returns label is attached, or that the RA number is clearly marked on the outside of the package and on any correspondence, before sending the instrument, freight paid, to Megger. Copies of the original purchase invoice and packing note should be sent simultaneously by airmail to expedite clearance through customs. In the case of instruments requiring repair outside the warranty period, an immediate quotation can be provided when obtaining the RA number.
5. You may track the progress of your return on line at www.megger.com

Approved Service Centres

A list of Approved Service Centres may be obtained from the UK address above, or from Megger's website at www.megger.com

Megger Limited
Archcliffe Road
Dover Kent, CT17 9EN
England
Tel: +44 (0) 1304 502100
Fax: +44 (0) 1304 207342

Megger
4271 Bronze Way
Dallas
TX 75237-1017 U.S.A.
Tel: +1 (800) 723-2861 (U.S.A. only)
Tel: +1 (214) 330-3203 (International)
Fax: +1 (214) 337-3038

Megger
Valley Forge Corporate Centre
2621 Van Buren Avenue
Norristown, PA 19403, USA
Tel: +1 (610) 676-8500
Fax: +1 (610) 676-8610

Megger SARL
Z.A. Du Buisson de la Couldre
23 rue Eugène Henaff
78190 TRAPPES
France
Tel : +33 (1) 30.16.08.90
Fax : +33 (1) 34.61.23.77

This instrument is manufactured in the United Kingdom.
The company reserves the right to change the specification or design without prior notice.

Megger is a registered trademark.

Printed in England V04_en_0310
www.megger.com