

Instruction Manual
for
Transformer Ohmmeter
50 A DC Winding Resistance Test Set
MTO250
Catalog Number MTO250

HIGH-VOLTAGE EQUIPMENT

Read this entire manual before operating the MTO250.

Megger®

Valley Forge Corporate Center
2621 Van Buren Avenue
Norristown, PA 19403-2329
U.S.A.

610-676-8500

www.megger.com

**Transformer Ohmmeter
50A DC Winding Resistance Test Set**

MTO250

Copyright © 2014 by Megger. All rights reserved.

The information presented in this manual is believed to be adequate for the intended use of the product. If the product or its individual instruments are used for purposes other than those specified herein, confirmation of their validity and suitability must be obtained from Megger. Refer to the warranty information below. Specifications are subject to change without notice.

WARRANTY

Products supplied by Megger are warranted against defects in material and workmanship for a period of one year following shipment. Our liability is specifically limited to replacing or repairing, at our option, defective equipment. Equipment returned to the factory for repair must be shipped prepaid and insured. Contact your MEGGER representative for instructions and a return authorization (RA) number. Please indicate all pertinent information, including problem symptoms. Also specify the serial number and the catalog number of the unit. This warranty does not include batteries, lamps or other expendable items, where the original manufacturer's warranty shall apply. We make no other warranty. The warranty is void in the event of abuse (failure to follow recommended operating procedures) or failure by the customer to perform specific maintenance as indicated in this manual.

Megger.

Valley Forge Corporate Center
2621 Van Buren Ave
Norristown, PA 19403-2329

610-676-8500 (Telephone)
610-676-8610 (Fax)

www.megger.com

Table of Contents

1 MTO250 General Information	1
Product Overview	1
Operational Functions and Applications	1
Top Panel Controls	3
2 Safety	9
Operator Responsibility.....	9
General Safety Precautions	10
Input Power Precautions.....	11
3 Specifications	13
4 Parts List and Optional Accessories	15
5 General Operating Procedures	17
Site Preparation.....	17
Making Connections to Specimen	18
Initial Testing	19
Common Test Procedure.....	20
Discharging a Transformer	21
Demagnetization Function	22
Using (Optional) Remote Switch	23
Stored Data Functions – Display/Delete/Download	24
Set Time Function.....	25
Set Time and Date Format	26
6 Transformer Testing	27
Fundamentals of Winding Resistance Testing	27
Testing a Single-Phase Transformer.....	28
Testing a Three-Phase Transformer	31
Testing Delta Configured Windings.....	35
Testing Transformers with Tap Changers	37
Testing Voltage Regulators	38
Demagnetizing a Transformer.....	40
Temperature Correction.....	41
7 MTO250 Series PowerDB Lite	43
Introduction	43
Using PowerDB Lite.....	43
Recommended Procedure for Data Storage & Download with Multiple Tap Transformer.....	48
8 Service	51
Maintenance	51
Firmware Update Mode	51
Calibration	52
Repairs.....	52
Error Codes.....	53

List of Figures

MTO250 Transformer Ohmmeter Test Set	iii
Figure 1: MTO250 Front Panel	3
Figure 2: Single Winding Measurement.....	28
Figure 3: Dual-Winding Test.....	30
Figure 4: Example of a Series Current Connection.....	32
Figure 5: Example of a Series Current 'Balanced' Connection	33
Figure 6: Reading obtained is one phase per test, Resistance of H1-H0 Winding	34
Figure 7: Reading obtained is between pairs of terminals, resistance $V = H1-H0$ winding and resistance $V2 = H3-H0$ winding (H2 terminal is used to obtain H0 measurement point)	34
Figure 8: Odd Position Tap	38
Figure 9: Even Position Tap	38
Figure 10: Connection to a Regulator.....	39

Upon Receipt of Product

Prior to operation, check for loosened hardware or damage incurred during transit. If these conditions are found, a safety hazard is possible, DO NOT attempt to operate equipment. Please contact Megger as soon as possible.



MTO250 Transformer Ohmmeter Test Set

Megger.

1

MTO250 General Information

Product Overview

The Megger Transformer Ohmmeter (MTO) is a line-operated, field-portable instrument designed specifically to measure the DC resistance of all types of magnetic windings safely and accurately. The MTO250 is also capable of testing non inductive low resistance objects such as breaker contacts, high current connections etc.

The MTO250's primary value is the measurement of the DC resistance of highly inductive transformer windings within the defined ranges of current and resistance. The MTO250 will also test rotating machine windings, shunt reactors and perform low-current resistance measurements on connections, contacts and control circuits.

Operational Functions and Applications

The MTO250 utilizes the Kelvin principle measurement, which allows the instrument to neglect the resistance of the leads connecting to the specimen. This method allows for various lead lengths without the need for lead compensation within the instrument.

Significant features combine to make the MTO250 safe to operate, designed for productivity and easy to use:

- Dual measurement and current injection
- Built in on-load tap-changer (LTC) make-break detection
- Automatic discharge when current path is interrupted
- Automatic demagnetization routine which allows for accurate SFRA and/or excitation testing to be conducted after winding resistance is completed.
- Dual potential measurements allows two readings to be measured at one time, either two phases on same side of winding, or one winding per primary and secondary.

The dual set of potential inputs, allows for either simultaneously measurement of the primary and secondary windings or 2 simultaneous phases of a three phase

wye winding (with neutral) of a transformer or motor/generator. This mode also speeds up the time to stable measurements because test current saturates the winding more quickly.

The transformer ohmmeter is useful when testing the windings and associated contact resistance on tap-changers with Load Tap Changers (LTC - also known as OLTC in IEC definitions). This includes voltage regulators which are simplified versions of a single or three phase transformers with LTC.

At the end of a transformer test, the MTO250 is able to demagnetize the winding(s) core under test. This demagnetization function cycles through the transformer with alternating variable pulse DC current. Once cycled through this process, the transformer phase which is connected will be demagnetized. Each phase tested with DC current will require cycling through this process. This testing process is more detailed in *Section 5 - MTO General Operating Procedures* of this manual.

Top Panel Controls



Figure 1: MTO250 Front Panel



Input AC Power Module:

This module is an IEC320 interface to the mains power. The module has an integrated switch and input filter module. The green light on the bottom of the module illuminates when power is ON.

The power input is acceptable from 85 to 264 volts from either a regulated line input or from a suitable stable source portable generator, where frequency must be between 47 and 63 hertz. Please be aware that at voltages below 120V, a potential for inadvertent tripping of the breaker does exist (under maximum load), although the MTO250 is self-protected.



Output Current Connector

This connector is used to connect to the transformer winding(s) and pass the DC power into the transformer winding for testing and demagnetization. The connection is capable of supplying 50 V dc and 50 A dc current. Connection is made via spade lugs on current test leads.



Input Voltage V1

These connections are used to connect a transformer winding for input voltage measurement. The instrument will automatically calculate the resistance of this input in combination with the current source. The connectors are also used as a path for current to flow during discharges. For maximum safety, voltage leads shall always be used in conjunction with current leads.



Input Voltage V2

These connections are used to connect a second transformer winding for input voltage measurement. The instrument will automatically calculate the resistance of this input in combination with the current source. The connectors are also used as a path for current to flow during discharges. For maximum safety, voltage leads shall always be used in conjunction with current leads. This measurement can be turned off by depress ► located on the left side of the front panel, but only prior to commencing a test.



Earth/Ground Lug

This connection is used to connect a transformer under test to earth ground for safety purposes and improving measurements while testing in high voltage/high electrical noise stations. The transformer and the MTO shall be at the power ground/earth potential when being operated.



Emergency Shut Down Switch

This switch, when pushed will disable the source power supply and automatically discharge the transformer. The instrument is continuously monitoring this switch in the event of an emergency. If the switch is engaged, no testing can commence.



Current Set Switch

This switch is used to control the test current applied to a transformer. Most standards specify 15% of rated current for the winding under test as a maximum recommended current. Example: 200A rated winding would be tested at the 25 Amp setting ($200A \times 15\% = 30A$; max allowable test current for this example).

Resistance readings remain accurate even when set test current is not reached, so long as a minimum 25% current setting is reached. It is recommended to reduce test current when current reading is below 25% of setting



HV Strobe Connector

When the optional HV Strobe is attached to the connector, the user will have a more visible indication of the activation mode of the MTO. This strobe is only active when current is flowing through the test current circuit, whether from the MTO, or discharge current from the charged test specimen.



Break Before Make INDICATOR

Blinking Lamp: If test current reduces >10% for a period exceeding "transition time sensitivity setting (set from $\Omega 2$ display). **Solid LED:** Indicates a 200msec hard limit was detected and unit automatically shuts down test current.

Depress  to continue when this condition is reached.

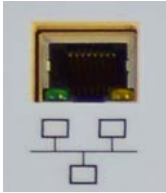

Ethernet Interface

This interface enables data download and MTO250 computer control (via PowerDB). This is also used to perform firmware upgrades.



Remote Control Switch

This connector is used to interface with an optional remote switch. This switch is primarily used for testing Load Tap Changer (LTC/OLTC) of a transformer.

The Remote Control Switch will remotely start the MTO test and store multiple resistance readings while making tap changes (LTC/OLTC type only). The storage function in remote mode is sequential and notes to the operator each stored value's record number. The unit also stores make-break transition events with each resistance. Details of procedure are available below.



Safety Interlock Connector

These connections are used when there is requirement for additional safety while testing a transformer. If the interlock is opened during testing, the unit will automatically begin shut down and discharge an energized transformer. Further testing will be prohibited until interlock is closed.

Data Output Mode Switch



MTO is in "Test Mode"



MTO is in "Data Review Mode"



MTO is in "Set Date/Time Mode"



MTO is in "Date Format Mode"

MORE DETAIL IS AVAILABLE ON DATA OUTPUT SWITCH OPERATION in *Section 5 - General Operating Procedures – Common Test Procedure.*

Megger.

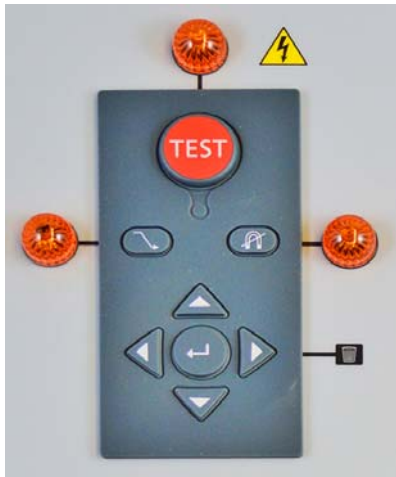

The TEST LAMP stays illuminated while current is flowing, whether in “test mode”, “demagnetization mode” or “current discharge” mode. This lamp is intended as a safety indicator which when lit indicates **Do Not Remove Test Leads**.



TEST BUTTON – When depressed, the MTO will start current flow to the object under test. When depressed while current is flowing, current will begin a discharge routine and the last resistance results will remain briefly on the $\Omega 1$ and $\Omega 2$ display.



When depressed, will start the current discharge process. The DISCHARGE LAMP to the left will illuminate during the discharge cycle. This performs the same action as depressing the TEST BUTTON while test current is on. Please note that for small specimens, lamp will only illuminate for a brief period.



When depressed, will perform a transformer demagnetization. The DEMAG LAMP to the right will illuminate during the demagnetization cycle. As well, each demag step is shown on $\Omega 1$ display and each demag current level is shown on the current display.



When depressed, the unit will acknowledge data enter (if testing), display additional information (in review), or confirm data deletion actions.



This symbol highlights that the ►X1 enables the user to DELETE the last recorded result in memory (◀ to confirm action). ►X2, enables the user to delete all results in a group (◀ to confirm action). ►X3 takes it out of the DELETE state.

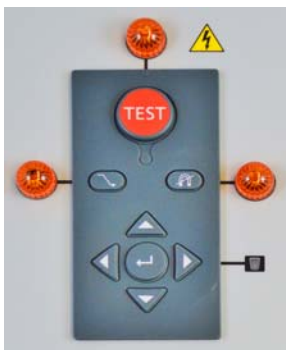

Current Display

This 6 digit display provides operator indication of test current level (provides 4 digits of resolution). Prior to test initiation when the instrument is ready to test, alternates 'ready' and 'Group-Result' of next available save. When reviewing saved results, this display indicates recorded current and 'Group-Result'.



Ω1 Display

This display provides operator indication of various parameters. Prior to test initiation, displays “temperature” setting for result storage, and is changed via ▲/▼ arrows. Once  is depressed, changes to display resistance value of V1 (4 digit resolution). During demagnetization initiation, displays progress via step numbers and indication when complete.



Ω2 Display

This display provides operator indication of various parameters. Prior to test initiation, displays LTC make/break sensitivity setting as well as Ω2 ON or OFF setting. LTC sensitivity is changed via ◀ arrow, and Ω2 ON or OFF is changed via ▶ arrows. Once  is depressed, changes to display resistance value of V2 (4 digit resolution).

Megger.

2

Safety

Operator Responsibility

Only qualified and trained operators should operate the MTO250 system. Operator must read and understand this entire Instruction Manual prior to operating the equipment. Operator must follow the instructions of this Instruction Manual and attend the equipment while the equipment is in use. In the event of equipment malfunction, the unit should immediately be de-energized and returned to Megger for repair.

“The Safety precautions herein are not intended to replace your Company’s Safety Procedures. Refer to e.g. *IEEE 62-1995/IEEE C57.152*, or IEC standards for additional information.



WARNING

When applying current to a transformer with very high inductance, additional care should be taken not to remove current or voltage leads while current is still flowing. This causes an extremely high voltage to develop across the point where current is broken. Under certain conditions, this voltage could prove to be lethal.

Safety is the most important design function within the MTO250. The MTO250 will protect the operator, the test specimen and itself with the following built-in functions:

- When input power is lost to the MTO250, the unit goes into automatic discharge and the discharge lamp stays illuminated until the stored energy within the transformer has dissipated within the test specimen.
- If the test lead is mistakenly disconnected while current is flowing, the MTO detects this action and immediately discharges the circuit.
- When a make-break LTC tap changer is under test, any “make-break event longer than 200ms triggers the discharge circuit and safely brings the current level to zero.
- The MTO is provided with both a standard interlock control as well as an optional HV Beacon, which helps maintain a safe operating site while testing.



WARNING

It is critical to connect leads securely to the bushings of transformers. Ensure that no strain is placed by leads while connected, so as to minimize the risk of inadvertent disconnection. The kelvin clip style terminations have strong spring pressure to ensure good connection, but one may also utilize a “tether” from lead connection to bushing for maximum precaution.

General Safety Precautions

The MTO and the Unit Under Test (UUT) should both be considered as sources of *instantaneously lethal levels* of electrical energy. Observe the following safety precautions:

- Observe all safety warnings on the equipment. They identify areas of immediate hazard that could result in injury or death.
- Use this equipment only for the purposes described in this manual. Observe strictly the Warning and Caution information provided in this manual.
- Treat all terminals of high-voltage power equipment systems as potential electric shock hazards. Use all practical safety precautions to prevent contact with energized parts of the equipment and related circuits.
- Use suitable barriers, barricades and/or warnings to keep persons not directly involved with the work away from test activities.
- Never connect the test equipment to energized equipment.
- Do not use in an explosive atmosphere.
- Use the grounding and connection procedures recommended in this manual. Always disconnect test leads from power equipment before attempting to disconnect them at the test set. The ground connection **MUST** be the first made and removed last. Any interruption of the grounding connection can create an electrical shock hazard.
- Personnel climbing higher than 5 feet (1.5 m) should follow proper tie off safety requirements.
- Personnel should use proper safety gear to prevent bodily harm.
- Personnel using heart pacemakers should obtain expert advice on the possible risks before operating this equipment or being close to the equipment during operation.

**WARNING**

No user serviceable parts inside! Refer all servicing to the factory or a qualified authorized service company!

**CAUTION**

**Use only factory supplied mains cord!
Mains cord shall not be substituted!**

Input Power Precautions

This instrument operates from a single-phase, sine wave, power source. It has a three-wire power cord and requires a two-pole, three-terminal (live, neutral, and ground) type input source. The voltage to ground from the live pole of the power source must be within the following rated operating voltage:

For Catalog No MTO250: 85 - 264 V, single-phase sine, 47-62 Hz >20%THD

The neutral pole must be at ground potential. Before making connection to the power source, determine that the instrument rating matches the voltage of the power source. The power input plug must be inserted only into a mating receptacle with a ground contact.

**WARNING**

Do not bypass the grounding connection. Any interruption of the grounding connection can create an electric shock hazard. Determine that the receptacle is properly wired before inserting power plug into the MTO250.

The control circuits of the instrument are protected by a circuit breaker which also acts as an on/off switch. Therefore, no fuses exist in the MTO250. The circuit breaker is rated at 15A and is fast tripping style. It also acts as an on-off switch for the MTO250.

Megger.

3

Specifications

INPUT	85 – 264 V 47 – 63 Hz >20%THD 1500VA
OUTPUT	
User Selectable Current Ranges:	1 A dc 10 A dc 25 A dc 50 A dc
Test Voltage:	50 V dc
RESISTANCE MEASUREMENT/DISPLAY	
Resistance:	@ 50A 10 $\mu\Omega$ to 40m Ω - auto ranging @ 50A 40 m Ω to 400m Ω auto ranging @ 25A 10 $\mu\Omega$ to 80m Ω - auto ranging @ 25A 80 m Ω to 800m Ω - auto ranging @ 10A 100 $\mu\Omega$ to 200m Ω - auto ranging @ 10A 200m Ω to 2 Ω - auto ranging @ 1A 1m Ω - 2 Ω - auto ranging @ 1A 2 Ω - 20 Ω - auto ranging
For resistance above 20Ω, test current will reduce (@ 1A setting) and readings up to 1000Ω can be measured with accuracy +/- 5% rdg.	
Accuracy:	$\pm 0.25\%$ reading, $\pm 0.25\%$ full scale
Resolution:	4 digits
Displays	Two 1" high, 6 character, 7-segment, LCDs One 0.71" high, 6 character, 7-segment, LCD
USER INTERFACE	B&W numeric displays, keypad
COMPUTER INTERFACE	Via Ethernet port
INTERNAL DATA STORAGE	9 groups (1-9) of results with 99 sets of results per group

SAFETY AND STANDARDS

Conforms to the emissions requirements of EN 61326-1:2006; Clause 7.2:

CISPR11 Edition 4:2003 Conducted Emissions, Group 1 Class A

CISPR11 Edition 4:2003 Radiated Emissions, Group 1 Class A

IEC 61000-3-2:2000 Harmonics

IEC 61000-3-3:2002 Flicker

Conforms to the immunity requirements of EN 61326-1:2006; Table 1:

IEC61000-4-2:2001 Electrostatic Discharge

IEC61000-4-3:2002 Radiated Immunity

IEC61000-4-4:2004 EFT/Burst, Power Ports and I/O Ports

IEC61000-4-5:2001 Surge Immunity, Power Ports

IEC61000-4-6:2003 Conducted Immunity, Power Ports and I/O Ports

IEC61000-4-8:1993, A1:2000 Power Frequency Magnetic Fields

IEC61000-4-11:2004 Voltage Dips and Interrupts

ENVIRONMENTAL

Operating: 14° F to 122° F (-10° C to 50° C)

Storage: -13° F to 158° F (-25° C to +70° C)

Relative Humidity: 0-90% non-condensing

DIMENSIONS

8.5 H x 21.5 W x 13 D
(216 H x 546 W x 330 D mm)

WEIGHT

Net 30 lb (13.6 kg)

4

Parts List and Optional Accessories

Item	Cat. No.
Transformer Ohmmeter	MTO250
120/230 volt, 50/60 Hz input	
<u>INCLUDED ACCESSORIES</u>	
Ground lead, 15 ft (4.6 m)	4702-7
AC power cord (IEC60320-C13 to US standard)	17032-23
AC power cord (IEC60320-C13 to Schuko CEE 7/7) AC power cord (IEC60320-C13 to US standard)	17032-19
In-lid Quick Start Guide	4702-7
Canvas carrying bag (for leadsets)	2005-265
Instruction manual	ATVMMTO250
PowerDB LITE software version	DB0001
<u>OPTIONAL ACCESSORIES</u>	
150KV Lead Set 30ft (9 m) c/w:	1004-640
30 ft (9 m) current Lead set Cat# 2000-787-30	
V1 30 ft (9 m) potential lead set Cat# 2000-700-30	
V2 30 ft (9 m) potential lead set Cat# 2000-701-30	
15 ft (4.5 m) current shorting lead Cat# 2000-788-15	
500KV Lead Set 60ft (18 m) c/w:	1004-641
60 ft (18 m) current Lead set Cat# 2000-787-60	
V1 60 ft (18 m) potential lead set Cat # 2000-700-60	
V2 60 ft (18 m) potential lead set Cat # 2000-701-60	
30 ft (9 m) current shorting lead Cat# 2000-788-30	
750KV Lead Set 100ft (30 m) c/w:	1004-642
100 ft (30 m) current Lead set, Cat# 2000-787-100	
V1 100 ft (30 m) potential lead set, Cat# 2000-700-100	
V2 100 ft (30 m) potential lead set, Cat# 2000-701-100	
50 ft (15 m) current shorting lead, Cat# 2000-788-50	
Universal Kelvin lead set, c/w current & potential leads, 30 ft (9 m)	2000-789-30
Universal Kelvin lead set, c/w current & potential leads, 60 ft (18 m)	2000-789-60
Universal Kelvin lead set, c/w current & potential leads, 100 ft (30 m)	2000-789-100
Hard sided transit case, c/w foam lining, for instrument and leads.	2005-258
HV Strobe (Beacon) c/w 60 ft lead (18 m)	1004-639
Remote Hand Switch c/w 60 ft (18 m) lead	30915-220

Megger.

5

General Operating Procedures

When testing high-voltage transformers, caution must be used at all times and all safety precautions followed. Read, understand, and employ all safety precautions and circuit connections described in *Section 2 - Safety*.



WARNING

Ensure that the transformer to be tested is completely de-energized. Check every winding. Ensure that all terminals of the transformer are disconnected from line or load at the transformer. Connections to ground may be left in place.





WARNING

For all testing as described herein, care shall be taken to ensure any and all unused clamps shall be isolated from each other, from ground, and from personnel.

EMERGENCY SHUTDOWN PROCEDURE

There are 4 methods to shut down test current to the MTO250. They are:



- Press red EMERGENCY TEST OFF push button 
- Depress the test button 
- Depress the discharge button 
- Turn the power button to OFF (O).

All actions above place the unit into “discharge mode”. Please note, discharge lamp will only stay illuminated for a brief time with small specimens.

Site Preparation

Choose a location that meets the following conditions:

- The location is as dry as possible.

- There is no flammable material stored in the vicinity.
- The test area is adequately ventilated.
- Be sure all equipment is de-energized and all terminals of the Unit Under Test (UUT) are accessible. Erect suitable safety barriers to protect the operator from traffic hazards and to prevent intrusion by unauthorized personnel. User provided Warning lights are recommended.
- Verify that the Local station ground is intact and has impedance continuity to earth.

Making Connections to Specimen

Connections should be made in the order as listed below.

1. **Ground.** Use the Megger supplied safety ground cable (15 ft (4.6 m)) to connect the MTO ground terminal directly to local station earth ground. Input power source ground terminal should be less than 100 m Ω of impedance to local station earth ground.
2. **Connect the Input Power Cord.** Before making this connection, insure the *Input Power Source* meets the requirements as listed in *Section 2 - Safety* and *Section 3 - Specifications*. Also ensure the ON(|)/OFF(O) switch (*Figure 1*) is in the OFF(O) position. Connect the input power cable to the MTO first, then to the power source.
3. **Connect the Ethernet Cable (optional).** If the user chooses to use a computer, using PowerDB Lite computer software, then connect the Ethernet cable between the MTO and the computer at this time.
4. **Connect the Remote Control Switch (optional).** If the user chooses to operate the *Test Button*  of the MTO from a remote distance, then connect the RCC cable at this time.
5. **Connect HV Strobe (optional).** Connect the HV Strobe cable at this time and place the beacon in a conspicuous location. Typically, one connects this HV strobe to an opposite side of the transformer using the magnetic portion of the HV strobe at a height suitable for individuals within the area to see it easily.
6. **Connect Interlock Switch (customer provided)** The MTO has an external interlock switch feature. Connect the external Interlock Switch via banana jack connection to the interlock input jacks on the front panel. The interlock switch function is a fail open, therefore if not used, an interlock jumper must be

placed in the jacks. If the circuit is open IntLoc will be displayed at the middle LCD.

- 7. **Connect current and potential leads (to the MTO end only at this time).** With the clamps disconnected from the UUT, connect the I and V cables to the MTO. Ensure all plugs are fastened securely to the MTO. Refer to Application *Section 5 - Transformer Testing* for specific conditions such as dual resistance, optimize saturation testing, etc.
- 8. **Connecting to the Transformer.** When testing high-voltage transformers, caution must be used at all times and all safety precautions followed. Read, understand, and employ all safety precautions and circuit connections described in *Section 2 - Safety*.

WARNING



Ensure that the transformer to be tested is completely de-energized. Check every winding. Ensure that all terminals of the transformer are disconnected from line or load at the transformer. Connections to ground may be left in place.

WARNING



For all testing as described herein, care shall be taken to ensure any and all unused clamps shall be isolated from each other, from ground, and from personnel.

Initial Testing

Once all the precautions and steps of *Section 2 - Safety* are complete, and the connections to the Unit Under Test (UUT) have been made, operator may switch ON (|) the MTO250. See below:

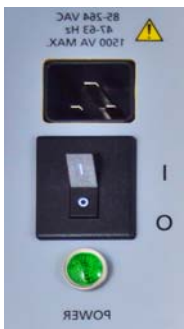

| , ON position
O, OFF position

On power up, an audible beep should be heard, and the MTO250 will perform a self-test check, validating hardware and internal firmware is properly operating.

If an error code is displayed that is uncorrectable, return the instrument to Megger or an authorized service center for repair. Refer to *Section 8 - Service - Maintenance* for a list of error codes. If no errors are detected, the current display will show “ready”.

Common Test Procedure

The user must set the proper test conditions. These are described below:

1. Set the **Function Mode Switch** to TEST  mode. This position is required for current to be initiated. Recommended levels are a maximum of 15% of rated transformer winding under test.





2. Set the **Current Range Switch** to the desired amplitude. Recommended levels are >15% of rated transformer winding under test. The highest current possible is recommended as the time to stable readings is reduced (in most cases).







3. The $\Omega 1$ window will display the temperature value that the unit will store with the resulting data for all subsequent tests. To change temperature setting depress $\blacktriangle/\blacktriangledown$ arrows to the desired value (this will not correct displayed resistance readings).
4. If one is testing LTC/OLTC (Load Tap Changer) positions of a transformer, a time saving method is to maintain energized current while changing tap positions (precautions in *Section 2 – Safety* should be followed). Operator should now set the make/break transition setting as displayed on $\Omega 2$. This setting is L0 to L4, and is changed via the \blacktriangleleft arrow. This setting is related to the sensitivity of the LTC/OLTC transition, and typically starts at L1 – 2ms (if used). If tap changer is not in optimum condition or of a poorer design, this setting is changed to L2-L4 (20 – 80ms) transition sensitivity. Set to L0 to disable.

5. Depress  and the unit will apply power to the transformer and charge the winding(s) under test to the maximum current set level. Once the current begins to stabilize, the unit will display resistance readings.
6. For the more highly inductive transformers, proper resistance readings may take additional time. This will be noted by the operator via the resistance display, which slowly falls or rises (example: by one digit per 10-15 seconds).

After a reading is stabilized, depress  to save displayed result (saves resistance, test current, temperature and make/break values for $\Omega 1$ and if ON, $\Omega 2$). Immediately after depressing , the record value for this result will be displayed on the current (I) display.

The  button makes it possible to record multiple readings while current is maintained for load tap changer units on transformers (LTC/OLTC). The MTO250 will toggle the stored test results record number in the current display every 2 seconds.

If a reading is mistakenly saved, the MTO250 has built in safe guards to minimizing this situation. The MTO250 waits 3 seconds before it allows another reading to be recorded. This minimizes accidental double pressing keys when saving results. If a reading is mistakenly taken, depressing , followed by  will delete the last saved record.

7. Pressing  a second time will begin the current discharge of the transformer, briefly displaying the last readings on the display. The discharge indicator will illuminate during the discharge, and turn off when complete. The result will stay on the display until another function or  is selected.

Discharging a Transformer





This button will stop testing and discharge the transformer. The *Discharge Indicator* to the left will illuminate during the discharge cycle.

Discharging a transformer after testing is critical to prevent excessive voltage buildup across the transformer bushings upon removal of current. The MTO provides 4 ways in which the discharge circuit is activated. When the current source is disconnected, the energy in a transformer will continue to flow. If there is high impedance (air), the voltage across the inductor will increase until there is a current path found for the energy. This can be either an internal or external current path. It is possible to attach a shorting cable across the transformer

bushings before the current source is turned off. Since the short has very little resistance, the circulating current thru the transformer and the short may continue for a very long period of time. The MTO discharge circuitry is built-in. It will automatically initiate when the current source is disconnected from the transformer. It will also provide visual indication of discharging via a lamp to the left of the  button.

There are 4 methods where the discharge test circuit in the MTO250 is activated (after test current is flowing). They are:

- Press red EMERGENCY TEST OFF push button .
- Depress the test button .
- Depress discharge button .
- Turn the Power button to OFF (O).

Demagnetization Function



This button will perform a transformer demagnetization. The *Demag Indicator* to the right will illuminate during the demagnetization cycle. In addition, the $\Omega 1$ display will show the progress and the current display will show each current magnitude step by step.

The demagnetization of a transformer after testing is critical for smooth transformer startup. If there is a large residual flux present in the transformer at startup, inrush currents on the primary side of the transformer may exceed relay settings for shutdown, therefore it is advantageous to perform demagnetization after a winding resistance test sequence has been run and the transformer is scheduled back into service.

The MTO demagnetizes the transformer by automatically magnetizing the core in the positive and negative direction with multiple cycles of reduced current. During the demagnetization, the unit will display the remaining number of cycles on $\Omega 1$.

Demagnetization should only to be performed once after all resistance testing is complete. For the most effective demagnetization, it has been determined that test leads should be attached to a high side winding, even if most testing is conducted on the low winding of the transformer. It has been determined for typical demagnetization of a core, the middle phase is used. This allows a balanced effect for demagnetizing all 3 phases.

The demagnetization cycle will take time for completion. It is equivalent to performing multiple tests in sequence.

Using (Optional) Remote Switch

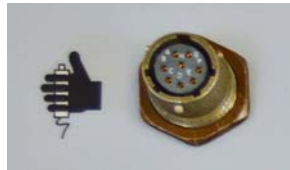

The main advantage of the remote test switch is to record sequential results while maintaining test current during a test. It is an efficient, time saving method of recording multiple resistance tap values when a Load Tap Changer (LTC/OLTC) is in the circuit. An even more efficient method involves connection of 2 windings in series on the LTC (OLTC) side of a transformer, and recording twice as many results over the same test time as above.

1. Connect *Remote Control Switch* (optional accessory) to the remote connector on the front panel of the instrument.



2. Power ON (|) the instrument.

The Unit will detect the remote switch and display 'r n n t 0/1' (rmt 0 or 1) on the $\Omega 1$ display. The '0' is displayed when the switch is open; the '1' is displayed when the switch is depressed. Depressing the remote switch prior to testing confirms proper operation of the remote switch.

3. To start a test sequence, depress  on the front panel. This will NOT begin charging transformer (when remote switch is in the circuit) but will illuminate the HV lamp in a flashing manner. The remote switch built in lamp will begin in the off state.
4. The operator should now validate that they are on the proper tap position on the transformer LTC(OLTC), and once confirmed, depress the remote switch  to begin the first test.

The remote indicator lamp will slow flash to indicate charging. The MTO250 HV lamp will now illuminate with a steady light to show current is flowing. When the remote indicator lamp becomes solid, the reading is displayed on the MTO250. This does not confirm a steady result, only that the reading is displayed. Different transformers require different stability times and as a rule of practice operator should view the first result value on the instrument and count the time (in seconds) to achieve a desirable steady value. This 'wait time' should be used for each tap position tested.



5. Depressing  the second time will save the result to memory. During this sequential testing, the MTO continues to monitor and save *Make/Break* transition events (as set by operator in $\Omega 2$ display at start of testing).



If a *Make-Break* event occurs, depending on the length of the break, one of two things will happen:

- i. **For short breaks**, the unit will rapidly flash, but the system will continue to operate and give resistance readings. This condition allows operator to continue testing using the remote switch.
- ii. **For breaks longer than about 200ms**, the current discharge circuit will be activated. The front panel test lamp will extinguish, the discharge lamp will illuminate and remote switch lamp will flash. Operator will no longer be able to continue testing until situation is corrected.

To correct situation, depress . This will record and clear the event.

6. If a 200ms *Make-Break* event occurs, depress  and then remote switch  to continue testing. This will re-activate the test current and begin to flash slowly until reading displays on the resistance display. See Step 4. Depress  a second time to continue recording.

Stored Data Functions – Display/Delete/Download



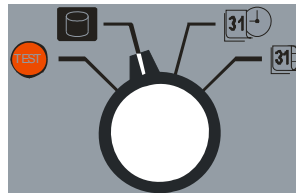



The MTO can save up to 891 (99 results per group in 9 groups) test results to memory for archival purposes. If data is stored while testing, the unit can step through the memory after testing in a review process.



1. Set the *Data Output Mode Switch* to  (stored results mode). The unit will display the last data stored including the results record number and the data group (1-9). The result record number, group number and time of test will

flash on the current (I) display. Depressing  will display detailed results of current and two resistance values. Pressing  will alternate between the two displays.

NOTE: When the MTO storage is full, the message "Stor.Ag FULL" will be displayed at power up or when reviewing data.



2. Depress ▲ and ▼ to scroll the stored data within a group. Depress  + ▲/▼ simultaneously to change the results 'group' (groups 1-9) to be viewed. Each record will display 'group# - record #' in the right portion of the current (I) display.
3. Depress ► to delete the stored data within the group displayed from the unit. The unit will ask for confirmation 'rst' on the Ω1 screen and 'SURE' on the Ω2 screen. Press  to confirm deletion.
4. Depressing ► a second time will begin a process to delete all stored data within the selected group from the unit. The unit will ask for confirmation 'grp' on the Ω1 screen and 'SURE' on the Ω2 screen. Press  to confirm deletion.
5. Depressing ► a third time will exit 'delete mode'.
6. **OVERWRITING AN EXISTING RECORD.** – From Steps 1 and 2, select the result to be overwritten. Depress . The Ω1 display will show 'retest'.
 Change switch position  to 'TEST' position. Depress  and follow Steps 1 to 6 as outlined in 'Common Test Procedure', above. This will replace existing record with new results.

Set Time Function

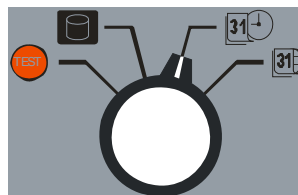
The MTO can set the Time of Day from the front panel interface. Set the function mode switch to the Date Time Setting as shown below.





Megger.

1. Set the function mode switch (above) to  set time mode. Date will display on MTO250 to show 'year' on current (I) display, 'day/month' on $\Omega 1$ and 'time' on $\Omega 2$ displays.
2. The first time change will be year on current (I) display (last 2 digits will be flashing). Use \blacktriangle and \blacktriangledown to change or if correct, depress \blacktriangleleft and \blacktriangleright arrows to navigate to next setting. The active parameter will blink on and off.
3. Use  to confirm change after *each* parameter change.

Set Time and Date Format

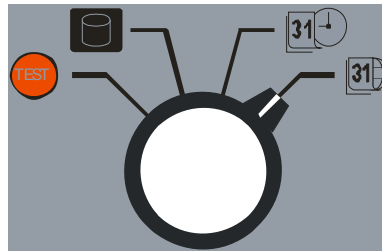
The MTO allows change in the Date Format. This will accommodate different international time standards.



1. Set the Function Mode Switch to Date Format Mode.
2. Depress \blacktriangle or \blacktriangledown arrow to select “year/month/day” to “month/day/year” to “day/month/year”.
3. Depress  to confirm any changes made to selected parameters.

6

Transformer Testing

Fundamentals of Winding Resistance Testing

Winding resistance measurements in transformers are of fundamental importance for the following purposes:

- As a maintenance tool to confirm proper operation of off-load (DETC) and on load (LTC/OLTC) tap changers of transformers.
- As a diagnostic tool for assessing the condition of inductive specimens such as transformer windings and motor/generator windings.
- Calculations of the I²R component of conductor losses.
- Calculation of winding temperature at the end of a transformer heat run test.

Measuring the resistance of the windings assures that the connections are correct and the resistance measurements indicate that there are no severe mismatches or opens. Many transformers have taps built into them. These taps allow ratio to be increased or decreased by fractions of a percent. Any of the ratio changes involve a mechanical movement of a contact from one position to another. These tap changes should also be checked during a winding resistance test.

Transformer winding resistances are measured to check for abnormalities due to loose connections, broken strands, and high-contact resistance in tap changers. Interpretation of results is usually based on a comparison of measurements made separately on each phase in the case of a wye-connected winding or between pairs of terminals on a delta-connected winding. Comparison may also be made with original data measured in the factory.

Testing a Single-Phase Transformer

Single-Winding Test

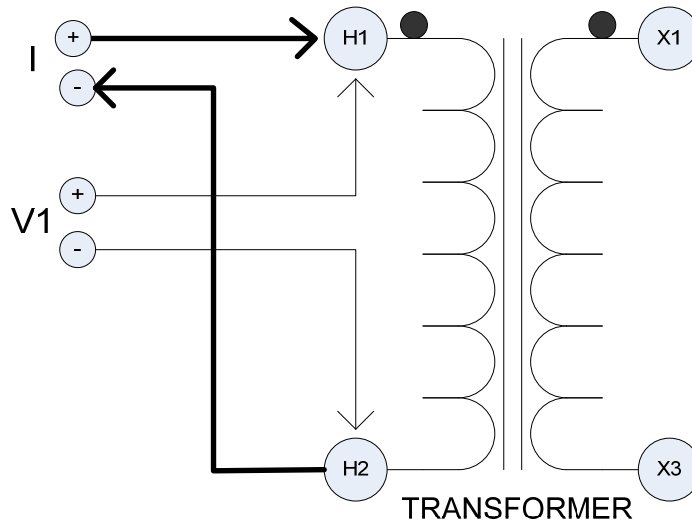

Figure 2: Single Winding Measurement



WARNING

Do not disconnect leads until all indicators are OFF!

PROCEDURE:

1. Connect line cord to unit and plug into a suitable power source. If using a generator, ensure that VA capability exceeds 1500VA and that THD <30%
2. Connect Safety GND cord from Top Panel to Transformer GND.
3. Set the following conditions:

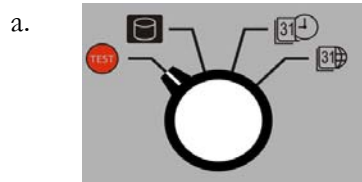

Set to **TEST** position.

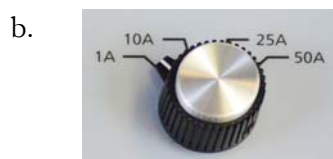

Set to desired **MAXIMUM TEST CURRENT**.

4. Connect current leads (I) to test specimen winding. See *Figure 2*.
5. Connect "V1" voltage leads to test specimen winding. **Voltage leads should always be placed inside (between) current leads and the transformer.** Do not place potential leads on the current leads, since this will add contact resistance to the measurement. Turn power switch ON (|).
6. Press  button to initiate current flow.
7. The top smaller display indicates current output and the Ω 1 display indicates resistance of specimen.

NOTE *The resistance display should be observed and resistance readings taken when the reading stabilizes. The drift in the indicated resistance reading is due to the inductance of the transformer. For small transformers the instability lasts for only a few seconds; for single-phase high voltage transformers (500kV), the instability may last for up to a minute; for large delta connected transformers the settling time may be much longer, see Testing Delta Configured Windings in this section.*

8. When measurement is complete, press  to terminate measurement and discharge current. Discharge is complete when the discharge indicator and the test current lamp are off.
9. Remove the current leads from the transformer.
10. Remove the potential leads from the transformer.

Dual-Winding Test

This procedure describes the testing of both windings (high and low) on a single-phase transformer at the same time.

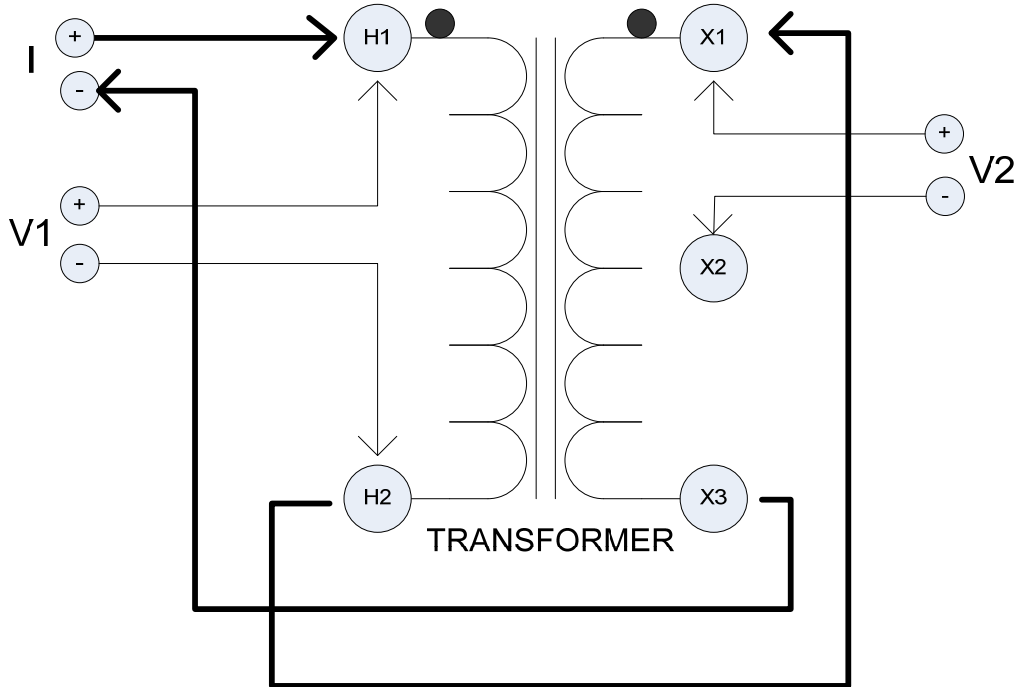

Figure 3: Dual-Winding Test



WARNING





Do not disconnect leads until all indicators are OFF!

NOTES: *It should be noted that the jumper in Figure 3 be connected to opposite polarities of transformer to reduce transformer core saturation time (H2 to X1 for this example). If the resistance between the 2 windings is greater than factor of 10, you may get a more accurate reading by testing the windings separately.*

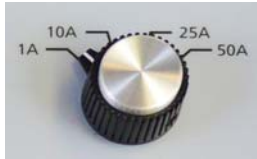
PROCEDURE:

1. Connect line cord to unit and plug into a suitable power source. If using a generator, ensure that VA capability exceeds 1500VA
2. Connect Safety GND cord from Top Panel to Transformer GND.
3. Set the following conditions:

- a.  Set to TEST position.
- b.  Set to desired MAXIMUM TEST CURRENT.

4. Connect "V1" voltage leads input to H1 and H2 terminals of test transformer. See *Figure 3*.
5. Connect "V2" voltage leads input to X1 and X2 terminals of test transformer. See *Figure 3*.
6. Turn power Switch "ON".
7. Press  to initiate current flow. The top display (I) indicates current output and the $\Omega 1$ display indicates resistance of primary winding and $\Omega 2$ display indicates the resistance of the secondary winding specimen.
8. When measurement is complete, depress  to end the measurement and discharge current or depress  button to record the result followed by  to end measurement. Discharge is complete when discharge and test lamp indicator is OFF – see below.

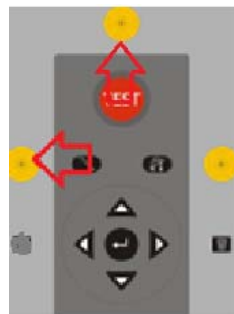

Testing a Three-Phase Transformer

General

The MTO250 has sufficient current to saturate and measure windings quickly, where only minutes per tap are required. It should be noted that with higher test current comes potential issues related to operator/transformer safety and with severe core magnetization. Below is application information related to testing transformers, but can be applied to shunt reactors and motors/generators.

Guidelines for Application of Test Current

Higher test currents typically reduce test time on highly inductive transformers and specimens. A general rule followed as per ANSI and IEC standards relates to restricting the DC test current to **15%** of the rated winding current. This does not mean we attempt to apply the full 15% in the form of DC test current. We look to apply sufficient test current to perform accurate results in a timely manner. General advice is to set current high enough to obtain accurate readings in a “suitable” time, but not too high to create issues when de-magnetizing the core. This is done by using a lower (eg: 10A) test current first, and if stability is not reached in a suitable manner increase current until such time as suitable readings are attained in a reasonable time – ensure that 15% rated current of winding under test is not exceeded.

Improving Reading Stability and Reducing Test Time

When testing transformers, one can improve the core saturation using two methods. The **first method** is connection of the primary and secondary winding in series via a shorting lead and applying current through both windings simultaneously. See *Figure 4*.

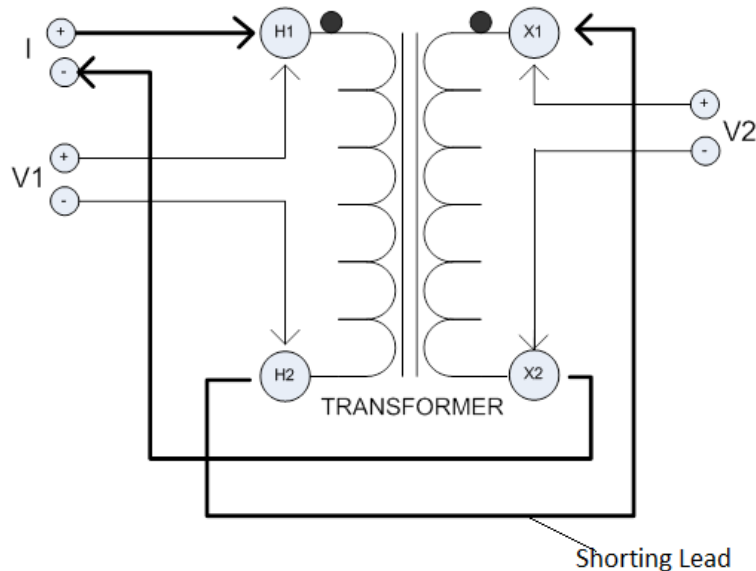

Figure 4: Example of a Series Current Connection

This method should only be used if sufficient test current can be applied. If primary winding is rated at a low current, it is more efficient to test the secondary side winding on its own – as we can apply a higher test current.

The **second method** for improving test time (reading stability) is to apply test current to windings in a balanced condition. This means applying test current to both outside windings in the first test and test the middle winding on its own as

the last test. This balance provides improved stability versus testing one phase at a time.

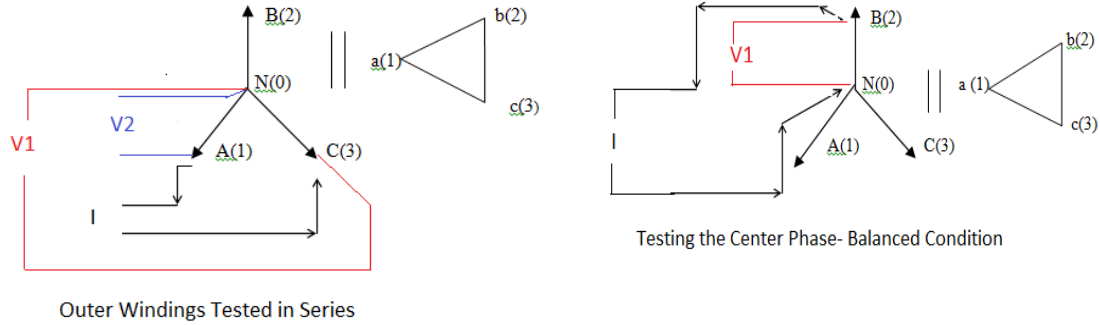

Figure 5: Example of a Series Current 'Balanced' Connection

The procedure below details the different methods to be used in testing three-phase transformers. The measurements taken will be for one or two winding(s) at a time. Connection diagrams (Figures 6 thru 10) are to be used in conjunction with procedure 'Single-Phase or Dual Winding Transformer Test' above. Main differences in testing relate to changes in placement of leads.

NOTE: *When testing Primary and Secondary windings simultaneously, always try and keep the polarization of the transformer in the same direction for improved transformer charge time. Table 1: 'Examples on Transformer Connection Schemes for Injecting Test Current and Measuring Two Windings Simultaneously' sets correct orientation.*

Wye Configured Windings

PROCEDURE:

1. **Three-Phase Wye Configured Winding with Neutral**

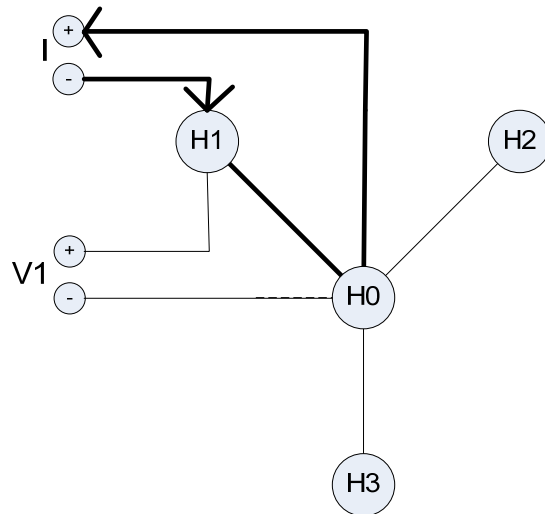

Figure 6: Reading obtained is one phase per test, Resistance of H1-H0 Winding

Use the above diagram in conjunction with procedure *Single-Phase Transformer Test*. Switch both current and potential leads for each phase tested. Always place the potential lead between the current lead and the transformer bushing for best accuracy.

Three-Phase Wye Configured Winding, No Accessible Neutral

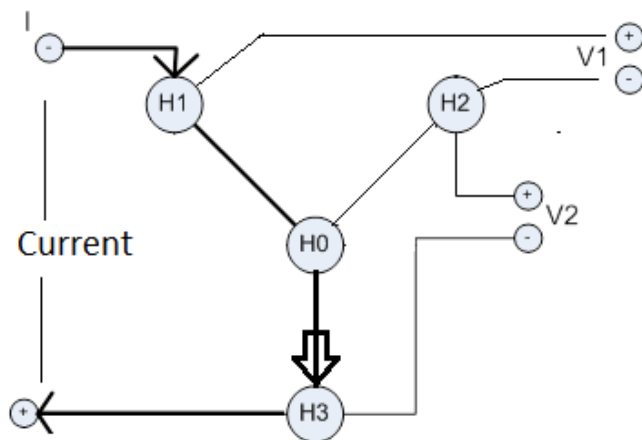

Figure 7: Reading obtained is between pairs of terminals, resistance $V = H1-H0$ winding and resistance $V2 = H3-H0$ winding (H2 terminal is used to obtain H0 measurement point)

Use the above diagram in conjunction with procedure *Dual Winding Transformer Test* above, except no shorting lead is required.

Note: Because H0 connection is inaccessible, the connection to the untested winding is used (H2 for this example) to obtain the H0 potential point. Although not exact, this is the best approximation for readings of phase to neutral windings.

Testing Delta Configured Windings

Testing transformers with delta windings may be a very time consuming procedure. LV delta windings may take up to 60 minutes (for very large transformers and when using a 10A test current) to obtain a stable result. When numerous tap readings are required, time restriction of many maintenance practices do not permit all the taps to be tested if time per test is too long.

The MTO250 has sufficient current and voltage to saturate and measure these windings quickly, where only minutes per tap are needed. It should be noted that with higher test current comes potential issues related to operator/transformer safety and with severe core magnetization.

A general rule followed as per ANSI and IEC standards relates to restricting the DC test current to 15% of the rated winding current. This does not mean we attempt to apply the full 15% in the form of test current. We look to apply sufficient test current to perform accurate results in a timely manner.

A method which is sometimes effective in quickly testing delta winding configurations requires that both the high side and low side be connected in series with the MTO's current source (see connection Table 1). By using both HV and LV windings to magnetize the core, the effective test magnetization current increases with the turns ratio. As an example, testing the Low Voltage side of a 100/10 kV Yd transformer with dual winding injection at 10A is the same as testing only the Low Voltage side of that same transformer 68 A. Even if only one side of the transformer needs to be tested, connecting both high and low windings in series may speed up the test.

Delta Winding Resistance

Manufacturer's winding resistance data are usually presented as per winding for Y configurations and per terminal pairs for Delta windings. In the rare case that manufacturer's data is presented per winding for a delta connection, the recommendation is to recalculate the numbers to terminal pairs and compare with the field measurement results.

R_{avg} = Average individual winding resistance

R_{tp} = Winding resistance between terminal pairs

$R_{tp} = R_{avg} * 0.6667$

TABLE 1.
EXAMPLES ON TRANSFORMER CONNECTION SCHEMES
FOR
INJECTING TEST CURRENT AND MEASURING TWO WINDINGS
SIMULTANEOUSLY

Vector Group	Measurement setup						
	Current Connections			Channel V1		Channel V2	
	+ Current	Jumper	- Current	+	-	+	-
Dd0	H1	H3-X1	X3	H1	H3	X1	X3
	H2	H1-X2	X1	H2	H1	X2	X1
	H3	H2-X3	X2	H3	H2	X3	X2
Dyn7	H1	H3-X0	X1	H1	H3	X0	X1
	H2	H1-X0	X2	H2	H1	X0	X2
	H3	H2-X0	X3	H3	H2	X0	X3
Dyn1	H1	H3-X1	X0	H1	H3	X1	X0
	H2	H1-X2	X0	H2	H1	X2	X0
	H3	H2-X3	X0	H3	H2	X3	X0
YNyn0	H1	H0-X1	X0	H1	H0	X1	X0
	H2	H0-X2	X0	H2	H0	X2	X0
	H3	H0-X3	X0	H3	H0	X3	X0
Ynd1	H1	H0-X1	X2	H1	H0	X1	X2
	H2	H0-X2	X3	H2	H0	X2	X3
	H3	H0-X3	X1	H3	H0	X3	X1
Dy1	H1	H3-X1	X2	H1	H3	X3	X2
	H2	H1-X2	X3	H2	H1	X1	X3
	H3	H2-X3	X1	H3	H2	X2	X1
YNd7	H1	H0-X2	X1	H1	H0	X2	X1
	H2	H0-X3	X2	H2	H0	X3	X2
	H3	H0-X1	X3	H3	H0	X1	X3
Dyn5	H1	H2-X0	X1	H1	H2	X0	X1
	H2	H3-X0	X2	H2	H3	X0	X2
	H3	H1-X0	X3	H3	H1	X0	X3
Dy11	H1	H3-X1	X3	H1	H3	X1	X3
	H2	H1-X2	X1	H2	H1	X2	X1
	H3	H2-X3	X2	H3	H2	X3	X2
Dyn11	H1	H2-X1	X0	H1	H2	X1	X0
	H2	H3-X2	X0	H2	H3	X2	X0
	H3	H1-X3	X0	H3	H1	X3	X0

Testing Transformers with Tap Changers

Many transformers used today have taps built into them. These taps allow ratio to be increased or decreased by a few percent. Any of the ratio changes involve a mechanical movement of a contact from one position to another. It is this contact that needs to be checked by way of its contact resistance and mechanical integrity.

The contact may go bad for a number of reasons.

- Misaligned when manufactured causing insufficient surface contact. Full load current overheats contact surface causing it to burn.
- Current passing through contact exceeds full load rating.
- Tap changing operation failing to have the required "make before break" sequence will create internal arcing of contact surface.
- An off-load tap changer is switched while on load. Contact surface becomes pitted and uneven.

Tap changers are divided into two types; 'on-load' (LTC/OLTC) and 'off-load' (DETC). The 'on-load' tap changer allows selection of ratio change while the transformer is in service. This would mean the ratio of a transformer can be changed while power (current) is still passing through it. The most common example of this type of "on-load" tap changer is a voltage regulator.

The MTO is equipped with a warning lamp which will flash as well as a displayed message code (**bb4m**). The internal discharge circuit will be triggered if the tap-changer contacts have a break before make event which exceeds 200ms (**error 472**). This action allows for both make-break detection as well as protection of MTO instrument and transformer under test. Once a detection event is noted, it is advised that the operator re-test the problem transition tap to validate that the problem was not a one-time event. Once a make before break transition detection is confirmed, operator should check tap changer for pitted or misaligned contacts, as well as for a weak spring mechanism.

The second type of tap changer is the 'off-load' (DETC). The MTO will test 'off-load' taps, but the transformer must be discharged between tap changes. If the transformer is not discharged between tap changes, damage may result in the transformer and/or the MTO test unit.

Testing Voltage Regulators

This procedure describes the basic connections to a single-phase regulator. The main test for a regulator is the evaluation of the condition of the tap positions. Because there are a large number of taps (typical 15 to 32), this test would normally take a very long time. With the MTO, this test time is drastically reduced because the instrument will stay on while changing 'on load' (LTC/OLTC) tap positions.

Many regulators have internal bridging reactors. It is because of these reactors that stabilization time for the MTO will vary. On odd position taps, balance time will be longer than even positions. This is due to circulating current generated when on odd positions and is shown below:

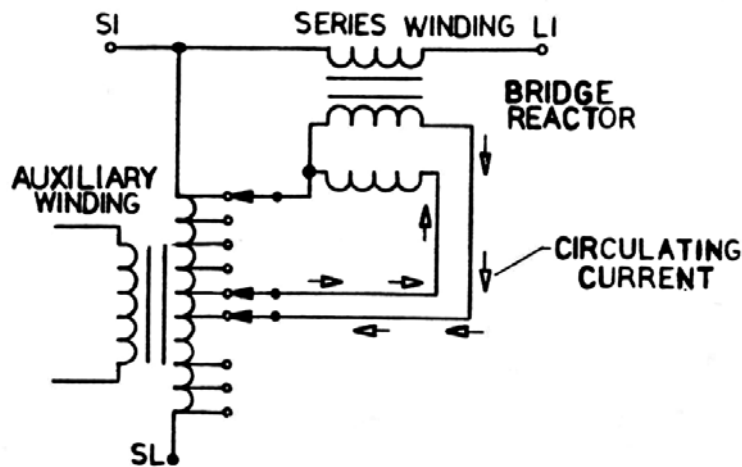

Figure 8: Odd Position Tap

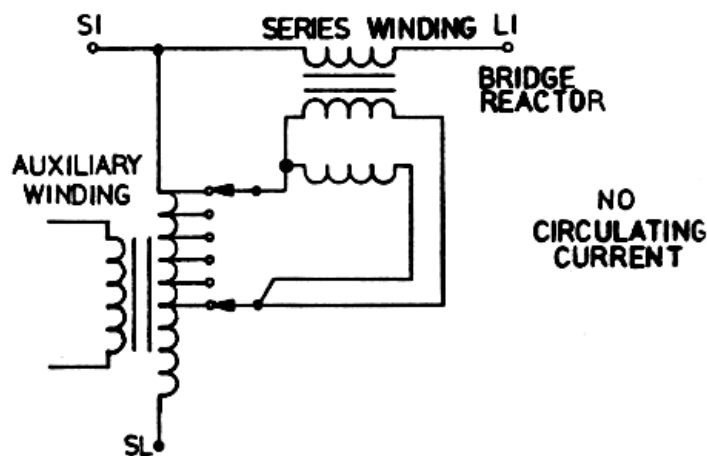

Figure 9: Even Position Tap

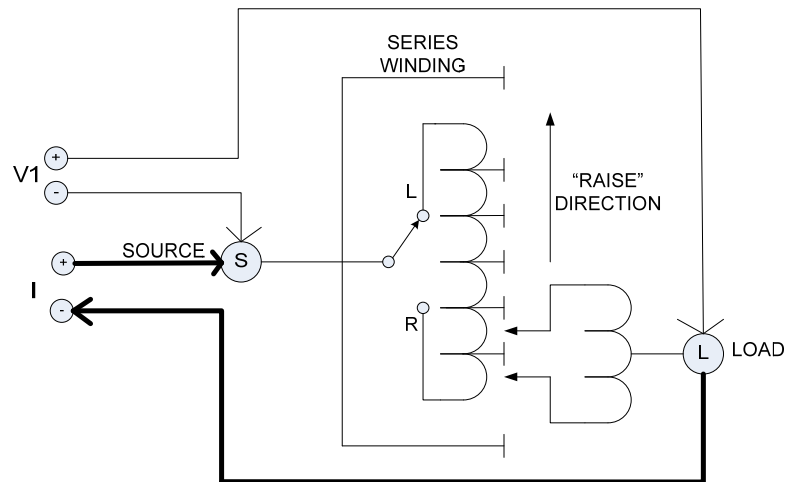

Figure 10: Connection to a Regulator



WARNING

Do not disconnect leads until all indicators are OFF.

PROCEDURE

1. Connect MTO to a suitable power source.
2. Set the following conditions:

a.

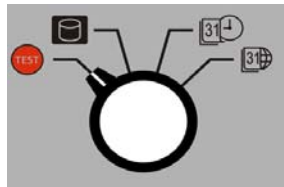



Set to **TEST** position.

b.



Set to desired Test Current.

3. Connect V1 voltage leads to test specimen winding. See Figure 10.
4. Connect current leads (I) to test specimen winding. Do not clip potential leads to the current leads, since this will add contact resistance to the measurement. **Potential leads should always be placed inside (between) the transformer and the current leads.** See Figure 10.



5. Turn power switch "ON" (|).
6. Press  button to initiate current flow.
7. The top display indicates current output and $\Omega 1$ display indicates resistance.
8. Step through the taps of the 'on load' (LTC/OLTC) tap changer. The resistance should change slightly with each tap change. Press  to save the readings for each tap.



If a *Break Before Make* condition occurs, the LTC Indicator will flash rapidly.



Depending on the length of the break, one of two things will happen.

1. **For short breaks (less than 200ms)**, the indicator lamp will flash intermittently, and the test current will continue to flow. Depress  to record and continue testing.
2. **For long breaks > 200ms**, the current will automatically discharge. The HV lamp will extinguish and the discharge lamp will flash (discharge lamp on time dependent on energy in specimen).

To continue testing after a long break before make event, depress . This will record and clear the display. Depress  to re-initialize test current and continue testing.

9. When measurements are complete, press  or  to discharge current. Discharge is complete when the discharge and test lamp are off.

Demagnetizing a Transformer

The MTO demagnetizes the transformer by automatically magnetizing the core in the positive and negative direction with multiple cycles of reduced current. The demagnetization function is equivalent to generating test currents for multiple resistance tests. During the demagnetizations process, the MTO250 will display:

- the number of cycles left in the process in $\Omega 1$ display
- the total demagnetization time on the $\Omega 2$ display
- the demagnetization current applied (-ve and +ve values)
- 'done' is displayed on $\Omega 1$ display once demagnetization is complete.

IMPORTANT POINTS RELATED TO THE DEMAGNETIZATION PROCESS:

1. Demagnetization is only required once after all resistance testing is complete.
2. Demagnetization time varies with inductance of transformer, and demagnetization current chosen. It may be as short as 3 minutes, but as long as 30 minutes.
3. Current and Voltage leads should be attached to one phase/terminal pair on high side (Primary) windings for more effective demagnetization.
4. Ensure voltage leads are attached as discharge energy is absorbed through the voltage leads.
5. For most transformers, it is only required that the middle winding (core) be connected for demagnetization. This is a good reason to save the middle phase as the last winding resistance test performed (saves connection time – more efficient). If demagnetization is not effective with single phase, one can perform demagnetization on all 3 windings of the high side of transformer. With this process, begin with outer phase and end with middle phase for best results.
6. For best demagnetization results, apply the same current as was used for winding resistance test. The MTO250 has an algorithm which calculates correct currents for each step in the demagnetization process.
7. If demagnetization process does not fully demagnetize transformer, operator can perform same demagnetization again (at same current) or increase to next highest current
8. If only low winding tested, one can demagnetize either low or high winding.
9. To validate level of magnetization, use before and after SFRA results or perform before and after excitation testing (for each phase). Any significant difference denotes residual magnetization. For proper demagnetization, difference should to be less than 3mA for excitation current (depending on size and construction of transformer)

Temperature Correction

It may be necessary to convert the resistance measurements to values corresponding to the reference temperature in the transformer test report.

To estimate the winding temperature at the measurement is important. If the transformer has winding temperature, use these readings. If not, the winding temperature is assumed to be the same as the oil temperature under the following conditions:

- The transformer has been out of service for at least 3 hours

- The temperature of the insulating liquid has stabilized, and the difference between the top and bottom temperature does not exceed 5°C.

If the transformer is measured without oil, the winding temperature is normally assumed to be the same temperature as the surrounding air.

Conversion of Resistance Measurements

Winding resistance measurements are normally converted to a standard reference temperature.

The conversions are accomplished by the following formula:

$$R_s = R_m (T_s + T_k) / (T_m + T_k)$$

where

R_s = resistance at desired temperature T_s

R_m = measured resistance

T_s = desired reference temperature

T_m = temperature at which resistance was measured

T_k = 234.5 (copper)

T_k = 225 (aluminum)

7

MTO250 Series PowerDB Lite

Introduction

PowerDB Lite is a free, but limited capability, version of the PowerDB software tool that is designed specifically to control and/or extract data from Megger instruments. The primary difference between PowerDB Lite and PowerDB is that PowerDB is designed to work with all manufacturers' equipment and has field and office synchronization capabilities. PowerDB Lite will present your test data into a professional looking data form that can be sent to a printer or .pdf file distiller such as PDF995.

PowerDB Lite allows you to use a sub-set of the standard PowerDB forms that are appropriate for specific Megger instruments. PowerDB Lite detects the instrument and enables the appropriate form(s). Data can be entered on-screen or captured directly while using the test instrument. Completed data forms can be saved as files to your computer.

For more information, or updates to the software, visit www.PowerDB.com.

Minimum Recommended System

- Operating System: Windows 2000 or later
- RAM: 64 MB RAM minimum, 512+ MB RAM recommended
- Processor: 300 MHz Pentium Class processor minimum, 1 GHZ or better recommended

Using PowerDB Lite

1. Instrument Setup Screen

1. Select **MTO-2XX** from the Instrument Setup Screen.
 - a. You can always view the Instrument Setup screen from the Tools menu or F3.

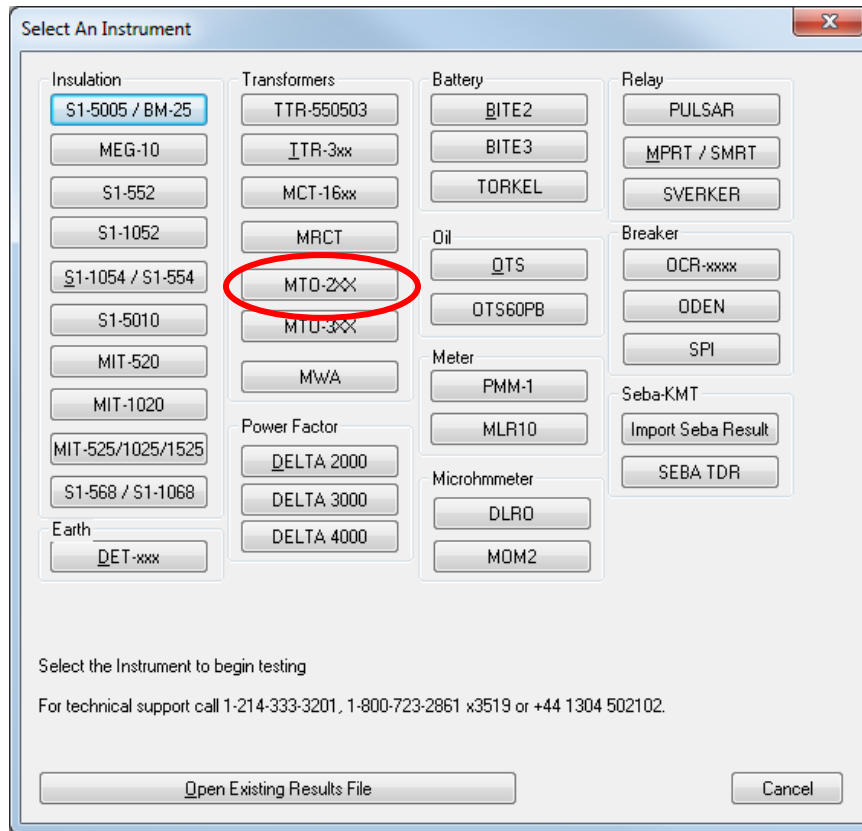

The MTO 250 uses Ethernet communication. This is the default selection and cannot be changed.

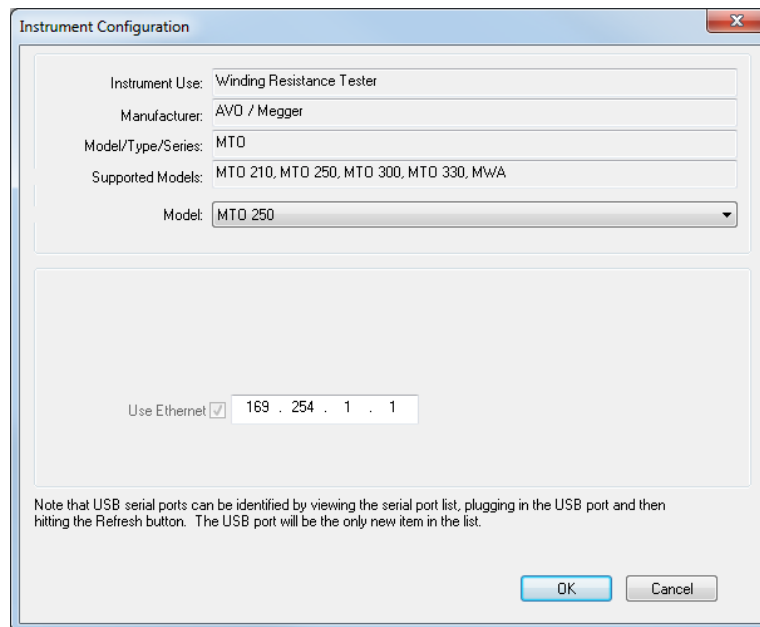

b. Click **OK** on the Instrument Setup Screen to finish.

2. Fill out the Form

Manually enter Header and Nameplate Information (for 2XX or 3Ø form)

3. Download Test Data (2XX form example)

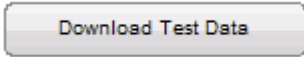
- Connect the MTO to your PC via Ethernet cable provided with instrument.
- Turn the MTO on.
- Wait minimum of 30 seconds, and then click . This action will draw the data from the MTO if connections are properly made. No action is required from MTO to have data sent to computer.

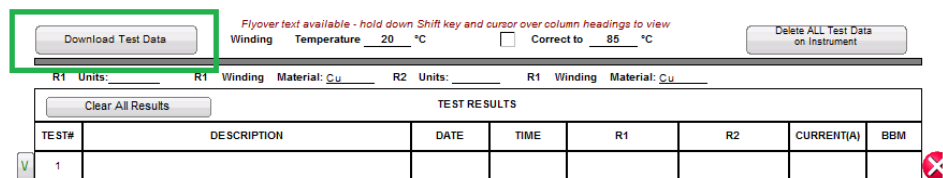

TEST#	DESCRIPTION	DATE	TIME	R1	R2	CURRENT(A)	BBM
1							

- Wait for PowerDB to download all of the data. The form will be populated automatically.

4. Manipulate Test Data

- Use the **Correct to** checkbox to change the results from actual readings to temperature corrected readings based off of Winding Temp and Correct To in the Nameplate data

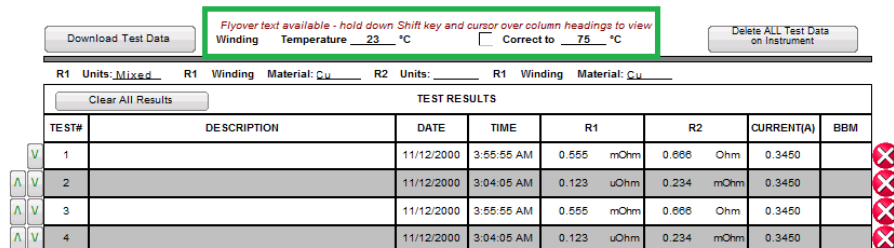

TEST#	DESCRIPTION	DATE	TIME	R1	R2	CURRENT(A)	BBM
1		11/12/2000	3:55:55 AM	0.555 mOhm	0.666 Ohm	0.3450	
2		11/12/2000	3:04:05 AM	0.123 uOhm	0.234 mOhm	0.3450	
3		11/12/2000	3:55:55 AM	0.555 mOhm	0.666 Ohm	0.3450	
4		11/12/2000	3:04:05 AM	0.123 uOhm	0.234 mOhm	0.3450	

- Change the units (Ω , $m\Omega$, $\mu\Omega$) for each column of resistance data by using the dropdown boxes labeled **R1 Units** & **R2 Units**.

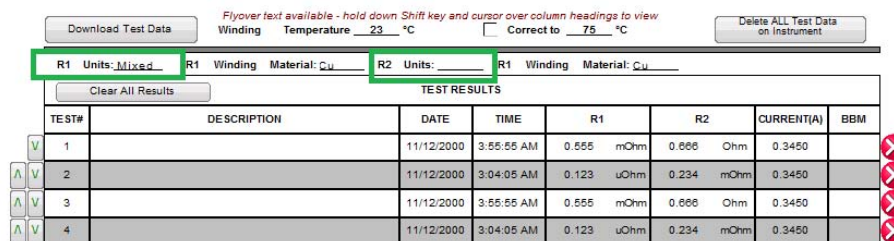

TEST#	DESCRIPTION	DATE	TIME	R1	R2	CURRENT(A)	BBM
1		11/12/2000	3:55:55 AM	0.555 mOhm	0.666 Ohm	0.3450	
2		11/12/2000	3:04:05 AM	0.123 uOhm	0.234 mOhm	0.3450	
3		11/12/2000	3:55:55 AM	0.555 mOhm	0.666 Ohm	0.3450	
4		11/12/2000	3:04:05 AM	0.123 uOhm	0.234 mOhm	0.3450	

- c. Move test data up/down using the green arrows to the left side of the resistance table data.

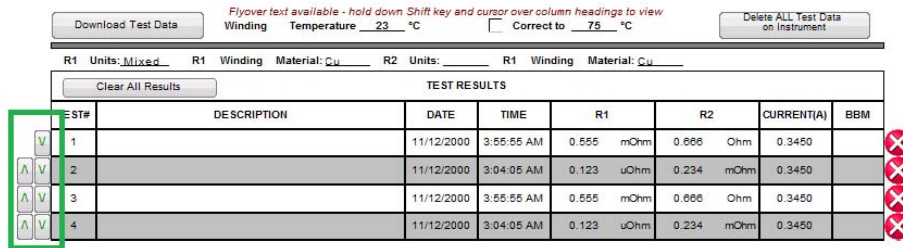

- d. Delete test data by clicking  to the right side of the resistance table data.

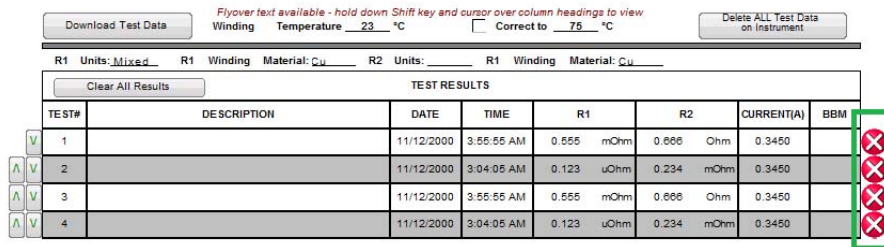

- e. Fill in Comments/Deficiencies, if applicable.

5. Optional: Delete All Test Data On Instrument

Press  to delete all of the test data on instrument.



6. Save The File

- a. Select File -> Save (or CTRL + s)
- b. Manually type in the File name you would like to use.

7. Open Saved Results

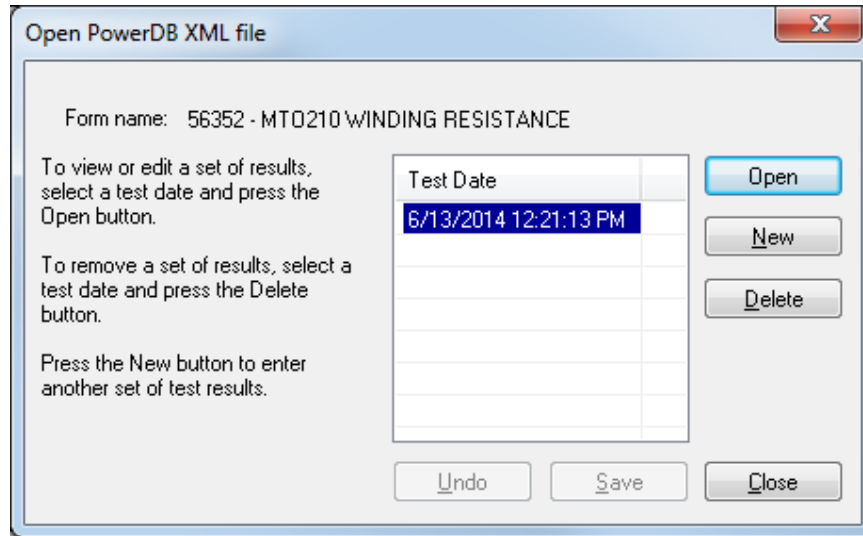
- a. Go to File -> Open (or CTRL + o)
- b. Navigate to your saved file directory and open the file.



- To add results to the file, click . This will create an additional result below original result labeled as a date.
- To view previously saved results, select the test date you want to view and click .
- To delete saved results, select the test date you want to delete and click .

8. SET LANGUAGE/MEASUREMENT/LOGO OPTIONS

- a. Select Tools -> Options...

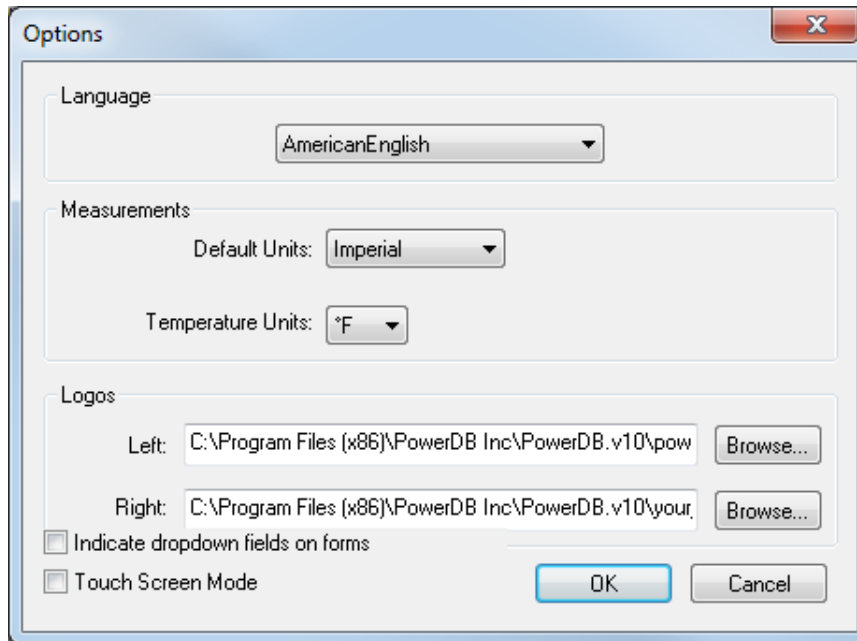

- b. Select the desired language from the dropdown box.
- c. Select the desired *Default Units* and *Temperature Units*.
- d. To change the right/left logo, click the browse button and navigate to the logo you wish to use.

Recommended Procedure for Data Storage & Download with Multiple Tap Transformer

1. Delete all existing test data on instrument (see procedure in *Section 5 - General Operating Procedures - Stored Data Function - Display/Delete/Download*).
2. Connect leads to measure two windings at the same time. See *Table 1-Examples on Transformer Connection Schemes for Injecting Test Current and Measuring Two Windings Simultaneously* as an example of how to connect the leads to take two measurements.
3. Measure the first two windings connected (typically phase A and phase C for balance) in the first Data Group. For LTC tap changers, begin at first tap, record, change tap without de-energizing test current, and continue recording until last tap is measured and recorded.
4. Connect leads to measure the last winding (phase B in this example), change the Data Group to number two, and turn off the R2 measurement.
5. Take measurements as in Step 3 above for R1.

6. Connect the MTO to your PC.
7. Download the test results to the PowerDB using the 3Ø form.

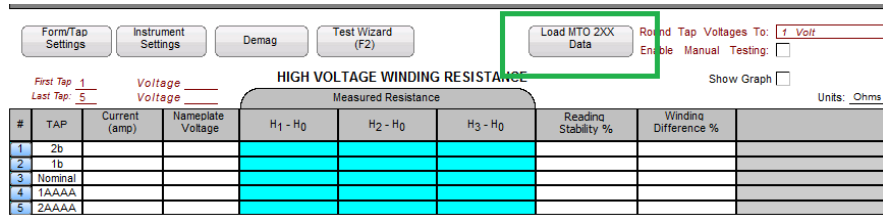

8. Use the options to configure the data import. This includes:
 - a. Selecting Primary/Secondary/Tertiary Winding
 - b. First/Last Tap
 - c. R1/R2 Phases for data
 - d. Group Number

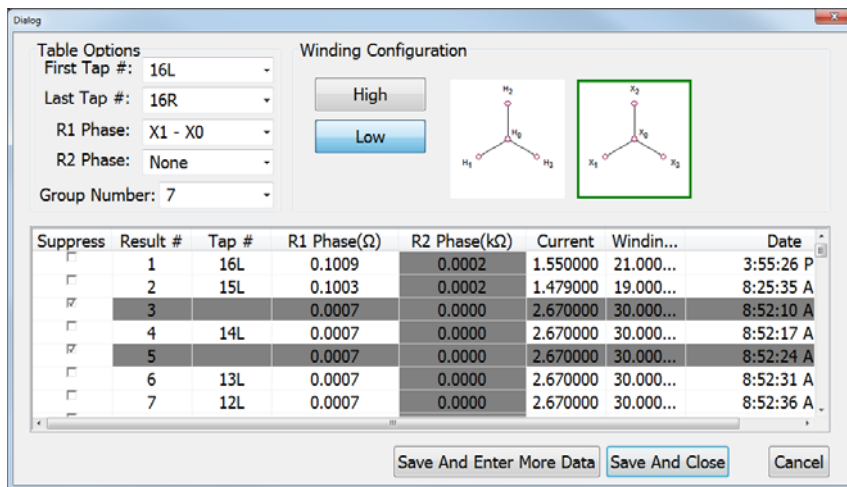

9. Results can be suppressed row by row by clicking the corresponding checkbox. The corresponding Tap# will adjust based on the rows suppressed.
10. Data can also be suppressed by choosing 'none' from the R1/R2 Phase.
11. Click *Save and Enter More Data* if you are entering more than one Phase. Click *Save and Close* when you are done entering data.
12. View the results on the graphs provided on the last page(s).

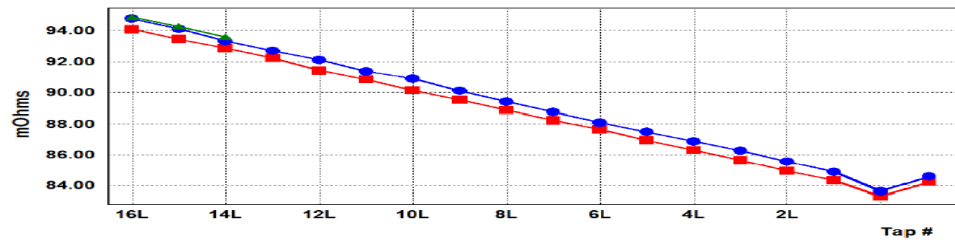

8

Service

Maintenance

Maintenance should be performed only by qualified persons familiar with the hazards involved with high-voltage test equipment. Read and understand *Section 2, Safety*, before performing any service.

Routine maintenance is required for the MTO test set.

The appearance of the MTO test set can be maintained by occasionally cleaning the case, panel and cable assemblies.

1. Clean the outside of the carrying case with detergent and water. Dry with a clean, dry cloth.
2. Clean the control panel with a cloth dampened with detergent and water. Do NOT allow water to penetrate panel holes, because damage to components on the underside may result. An all-purpose, household spray cleaner can be used to clean the panel. Polish with a soft, dry cloth, taking care not to scratch the display screen cover.
3. Clean the cables and mating panel receptacles with isopropyl or denatured alcohol applied with a clean cloth.
4. Inspect the cable assemblies occasionally to ensure they are in good condition.

Firmware Update Mode

The MTO has two processors, commonly referred to as the bottom and top processor. Each processor requires software to function properly. This section describes the method for changing the firmware on an MTO.

ATTAINING THE LATEST FIRMWARE:

In the event of an instrument failure, it is recommended the instrument be sent to an authorized Megger repair facility. If only firmware upgrade is required, the best way to attain the latest software is to visit www.Megger.com.

Once you are on the site,

1. Select the country you are located.

- You must register to the Log In portion of the website.

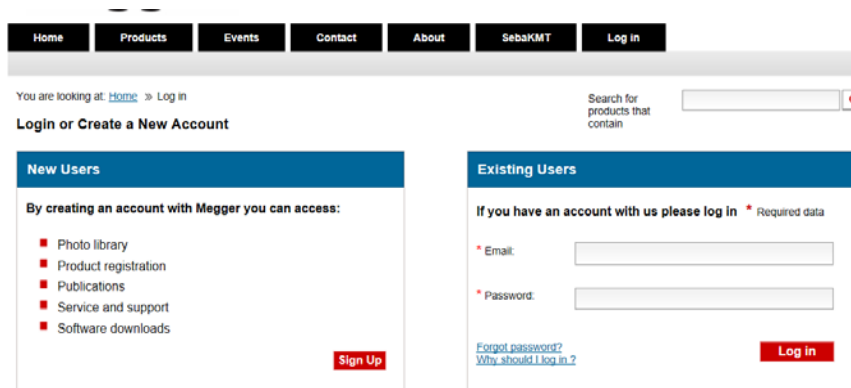

- Select *Software Downloads*.
- Select MTO. Below is the portion pertaining to both MTO210 and MTO250

MTO210 File Updates: (will open in a new window)
Choose from the list below

	Size	Last Updated
MTO210: Instructions: 37178 MTO Quick Guide Rev 2	103KB	March 22nd 2011
MTO210: Instructions: MTO210_Update_Instructions_1.1	388 KB	August 31st 2012
MTO210: UpdateMTO210 T2 B3.1	504KB	August 21st 2012

- Follow instructions to complete upgrade to latest firmware revision.

Calibration

A complete performance and calibration check should be made at least once every year. This will ensure that the MTO test set is functioning and calibrated properly over the entire measurement range. The MTO calibration is performed on each new or repaired unit before sending it to a customer. There is a special MTO final calibration procedure which requires a NIST-traceable test equipment to be used. As a result of such calibration procedure, each MTO test set may be NIST certified.

Repairs

Any service or repair of this equipment should only be performed by qualified persons who are aware of electrical hazards and the necessary precautions required to prevent injury.

Megger offers a complete Repair and Calibration Service and recommends that its customers take advantage of this service for routine maintenance or in the event of any equipment malfunction.

In the event that Service is required, contact your Megger representative for a product Return Authorization (RA) number and shipping instructions.

Ship the product prepaid and insured and marked for the attention of the Megger Repair Department. Please indicate all pertinent information, including catalog number, serial number, and problem symptoms.

Error Codes

The MTO comes with a wide range of error codes to assure unit is working properly and track down problems in a systematic manner. When an error code is observed, the problem may be caused through an internal issue (no possible correction by operator) or through an application error (a correctable situation). The first step once an error is displayed is to acknowledge the error by pressing  and repeating the test or sequence. If the error persists, review the list below or as is noted on the *Quick Guide* and determine if cause is correctable. If the error is not found below, please record error number; contact Megger (or an authorized Megger Service Center) for additional assistance. **Bold Error** codes with the possible causes are defined below.

CODE	Error Description	Possible Cause
ESd	ESD is in depressed state	Button is pushed down
IntLoc	Interlock is open	Interlock Jumper removed
1XX	<i>Ethernet and top panel errors (MTO2XX ONLY)</i>	
102	Ethernet communication failed	When connected to PC, check connection to computer
2XX	<i>Initialization errors</i>	
214	EsD – Emergency Off Switch	Emergency Switch closed. Lift to disengage.
243	Discharge circuit -temperature too high. Unit overheated.	Fans not operational, long continuous use, extreme hot test conditions
244	VICOR circuit -temperature too high. Unit overheated.	Fans not operational, long continuous use, extremely hot test conditions
3XX	<i>ADC_ERROR</i>	
4XX	<i>HARDWARE_ERROR</i>	
411	Current output not insufficient for range selected	Resistance of specimen too high for current range selected, poor current lead connection

Megger.

CODE	Error Description	Possible Cause
468	Received abort signal	Message only with MTO software - test was aborted within the software by user.
471	Current not flowing properly while charging	Current leads not connected properly or problem with specimen
472	Break before make condition	Lead removed during testing. Test specimen LTC has problems. This condition is created when >10% current change during testing.
480	Current = 0	Test enabled, with no current output, check lead connections.
494	ESD Abort signal encountered	Switch pushed down during test