

**Instruction Manual  
for  
Dual Range  
Battery Ground Fault Tracer**

*Patent No. 4,546,309*

HIGH-VOLTAGE EQUIPMENT  
Read this entire manual before operating.

APARATO DE ALTO VOLTAJE  
Ante de operar este producto lea este manual enteramente.

**Megger**<sup>®</sup>

Valley Forge Corporate Center  
2621 Van Buren Avenue  
Norristown, PA 19403 U.S.A.

610-676-8500 (Telephone)  
610-676-8610 (Fax)

[www.megger.com](http://www.megger.com)



***Dual Range  
Battery Ground  
Fault Tracer***

***Instruction Manual***

**Copyright © 2014 by Megger. All rights reserved.**

The information presented in this manual is believed to be adequate for the intended use of the product. If the product or its individual instruments are used for purposes other than those specified herein, confirmation of their validity and suitability must be obtained from Megger. Refer to the warranty information below. Specifications are subject to change without notice.

## **WARRANTY**

Products supplied by Megger are warranted against defects in material and workmanship for a period of one year following shipment. Our liability is specifically limited to replacing or repairing, at our option, defective equipment. Equipment returned to the factory for repair must be shipped prepaid and insured. Contact your Megger representative for instructions and a return authorization (RA) number. Please indicate all pertinent information, including problem symptoms. Also specify the serial number and the catalog number of the unit. This warranty does not include batteries, lamps or other expendable items, where the original manufacturer's warranty shall apply. We make no other warranty. The warranty is void in the event of abuse (failure to follow recommended operating procedures) or failure by the customer to perform specific maintenance as indicated in this manual.

## **Megger.**

Valley Forge Corporate Center  
2621 Van Buren Avenue  
Norristown, PA 19403 U.S.A.

610-676-8500 (Telephone)  
610-676-8610 (Fax)

*[www.megger.com](http://www.megger.com)*

# Contents

1	INTRODUCTION.....	1
	About the Dual Range BGFT.....	1
	How the Dual Range BGFT Works.....	2
	Applications for the Dual Range BGFT.....	3
	Upon Receipt of the Dual Range BGFT.....	3
	Safety First.....	4
	How to Use This Manual.....	4
	Typographic Conventions.....	4
2	SAFETY.....	7
	Overview.....	7
	Connection to Power Source.....	8
	Fuse Replacement.....	9
3	CONTROLS, INDICATORS AND CONNECTORS .....	11
	Overview.....	11
	Transmitter.....	12
	Receiver.....	14
	Current Probe .....	15
4	OPERATION.....	17
	General.....	17
	Transmitter Connections.....	17
	Configuring the BGFT .....	18
	Applying Transmitter Test Voltage .....	19
	Receiver Connections and Applying Power.....	20
	Defining The Fault.....	20
	Bridge Operation.....	21
	Tracing The Fault.....	22
	Instrument Shutdown Procedure.....	22
5	APPLICATION NOTES .....	23
6	MAINTENANCE & REPAIR.....	29
	Maintenance .....	29
	DC fuse Test and Replacement .....	30
	Amplifier Output Fuse Test and Replacement.....	31
	AC line Fuse Test and Replacement .....	32
	Changing voltage selector settings.....	32
	Battery Replacement (Receiver) .....	33
	Repair .....	33
	Specifications & replaceable parts .....	35
	Specifications.....	35
	Environmental.....	35
	Transmitter.....	35
	Operational .....	36
	Receiver .....	36
	Standard Accessories .....	36
	Replaceable Parts List .....	37

## LIST OF FIGURES

Figure 1: Dual Range Battery Ground Fault Tracer and Accessories .....	4
Figure 2: Transmitter Control Panel .....	12
Figure 3: Receiver Case (Front/Back) .....	14
Figure 4: Test Connections.....	19
Figure 5: On-Line Diagram of Example .....	24
Figure 6: Panel 31 AB.....	26
Figure 7: Terminal Block MM.....	27
Figure 8: Main Distribution Panels .....	28
Figure 9: Voltage Selector Card Orientation.....	32

# 1

## INTRODUCTION

### ***About the Dual Range BGFT...***

***NOTE:*** Before attempting to use the Dual Range BGFT, be sure that you read and understand the safety requirements and operating procedures contained in this manual.

Thank you for selecting a Megger product. This instrument has been thoroughly tested and inspected to meet rigid specifications before being shipped.

It is ready for use when set up and operated as described in this manual.

This manual contains instructions for the operation of the Dual Range Battery Ground Fault Tracer. See Figure 1. The equipment comprises a transmitter, receiver, source leads, current probe, feedback cable, and instruction manual. The transmitter is housed in a rugged plastic enclosure; the other items are housed in a separate accessories bag.

The Dual Range Battery Ground Fault Tracer locates ground faults in ungrounded DC battery systems. Various standards require action when the impedance between any battery polarity and earth ground falls below a specified limit. In the case of nuclear-fueled plants, the Nuclear Regulatory Commission (NRC) requires audits and appropriate action when this impedance is deemed unsafe. Other facilities come under the guidelines of the National Electric Code, NFPA, IEEE standards, and OSHA requirements for safe operation of DC battery systems in an ungrounded environment.

## ***How the Dual Range BGFT Works***

The Dual Range Battery Ground Fault Tracer applies a 20 Hz signal between the battery bus and station ground. This is accomplished by connecting the transmitter via the source leads to an accessible battery bus and to a ground bus located in a distribution cabinet. A two-step process then begins to identify both the magnitude and location of the fault. First, suspect feeder cables are identified by measuring the flow of fault current to ground on all the output circuits from the cabinet.

The amplitude of the 20Hz signal can be limited to either 15VAC, in the low range or 50VAC in the high range. The low range should be used when tracing low impedance faults below 100K ohms. The high range should be used for high impedance faults above 100Kohms; such as those caused by water ingress.

A bridge balance measurement can be performed to determine the value of the capacitance and resistance of the suspected ground fault. This is typically performed if more than one feeder cable is found that contains a fault current.

The resistance and capacitance bridge located on the transmitter is used to determine the value of the fault impedance in real and imaginary terms (resistance and capacitive reactance) while the amplitude of the signal current injected into the suspect feeder cable is monitored with the receiver. Three stages of amplification can be selected to identify and find faults to 399 k $\Omega$ . The red feedback wire (supplied) is used as a canceling feature for the injected signal as compared with the bridge selected impedance.

Isolating the fault to a specific location may require moving the equipment downstream in a distribution system. Once a fault resistance is quantified, the bridge and feedback portion of the procedure can be dismissed and the fault can be tracked by evaluating feeder lines of a subpanel. If the current value decreases after several steady or increasing readings, then the location is in the opposite direction.

## ***Applications for the Dual Range BGFT***

The BGFT, Dual Range Battery Ground Fault Tracer, can find ground faults in ungrounded battery systems in:

- Substations
- Generating Stations
- UPS Systems
- Any other ungrounded DC system

For information about other installations that might benefit from impedance testing, contact Megger.

## ***Upon Receipt of the Dual Range BGFT***

Check the equipment received against the packing list to ensure that all materials are present. Notify Megger of any shortage. Telephone (610) 676-8500.

Examine the instrument for damage received in transit. If any damage is discovered, file a claim with the carrier at once and notify Megger or its nearest authorized sales representative, giving a detailed description of the damage.

This instrument has been thoroughly tested and inspected to meet rigid specifications before being shipped. It is ready for use when set up as indicated in this manual.

The BGFT instrument is shown in Figure 1. The BGFT includes the following components and accessories.

- |                                |                                |
|--------------------------------|--------------------------------|
| ▪ transmitter                  | ▪ clamp-on current sensor (CT) |
| ▪ receiver with 9-volt battery | ▪ feedback loop                |
| ▪ current source leads         | ▪ line cord                    |
|                                | ▪ instruction manual           |



Figure 1: Dual Range Battery Ground Fault Tracer and Accessories

## Safety First

Be sure to read the safety information in *Section 2* thoroughly and observe all safety precautions and recommendations.

## How to Use This Manual

### Typographic Conventions

Figures and tables are numbered in sequence by section.

Numbered lists show procedural steps.

Bullets list items and options.

Buttons represent elements on the Dual Range BGFT control panel.

*Cautions alert you to possible damage to equipment.*



#### CAUTION

Never allow water to enter the case of the BGFT.

**Warnings** alert you to conditions that are potentially hazardous to people.

**WARNING**

Always power off and disconnect the Dual Range BGFT before cleaning it.

**Notes** provide important information.

**NOTE:** Very high impedances exhibit low resolution readings on the receiver. To obtain better resolution, wrap an additional turn around the clamp-on jaws of the current probe thereby doubling the fault current. Remember to divide the bridge capacitance by the number of turns and to multiply the bridge resistance by the number of turns to identify the fault impedance.

**Margin notes** offer extra information and assistance.

**Symbols used on the instrument are:**



**Caution:** refer to accompanying notes.



**Warning:** refer to accompanying notes.



Equipment complies with current EU directives.

**WEEE**

The crossed-out wheeled bin placed on Megger products is a reminder *not* to dispose of the product at the end of its life with general waste. Megger is registered in the UK as a Producer of Electrical and Electronic Equipment. The Registration No is WEE/DJ2235XR.

**Megger**<sup>®</sup>

# 2

## SAFETY

### *Overview*

The Dual Range BGFT and its recommended operating procedures have been designed with careful attention to safety. However, it is not possible to eliminate all hazards from electrical test equipment or to foresee every possible hazard that may occur. The user not only must follow the safety precautions contained in this manual, but also must carefully consider all safety aspects of the operation before proceeding.

It should be understood that any use of electricity inherently involves some degree of safety hazard. While every effort has been made by Megger to reduce the hazard, the user must assume responsibility for his own safety. Any work on large batteries is hazardous and requires constant attention to safety; particularly guard against the possibility of acid spills, explosion, and electrical shock.

The responsibility of the user is not limited to his/her own safety; he/she must also be responsible for all persons in the vicinity. The distribution system to which the Dual Range Battery Ground Fault Tracer is connected can be extensive and therefore the user must be aware of the consequences of applying up to 50 Vac to the DC system and the effect on the operation and safety of the entire system.

The Dual Range BGFT has been designed to the IEC61010-1 safety standards. Observe all industry standard safety rules for tracing ground faults.

- The Dual Range Battery Ground Fault Tracer is designed for connection to energized systems. Keep the power on/off switch set to 0 (off) when making connections or disconnections at the battery. The output of the Dual Range Battery Ground Fault Tracer and the system to which it is connected are sources of high voltage. Always wear rubber gloves during these operations.
- Safety is the responsibility of the user.
- The purpose of this equipment is limited to use as described in this manual. Do not use the equipment or its accessories for any purpose other than specifically described.
- Do not operate in an explosive atmosphere. Explosive gases can be present around batteries. A properly vented battery environment is considered safe, but it is the responsibility of the user to verify conditions prior to using the Dual Range Battery Ground Fault Tracer.

- Wear protective clothing and eye protection to guard against skin and eye damage from battery acid.
- Ensure that test leads and probes are in good condition, clean and free of broken or cracked insulation.

Observe the following cautions marked on the transmitter panel.

1. For use on ungrounded systems only.
2. Set power switch to off prior to connecting or disconnecting output leads to battery.
3. Connect output leads to J3 before connecting to battery system.
4. Ensure output ground connection is made to system earth ground.
5. Adhere to all industry standards for testing battery systems.

This instrument is only to be used by suitably trained personnel who are familiar with the hazards involved in testing high-voltage DC systems.



#### CAUTION

**Refer fuse replacement to qualified service personnel only. To prevent electric shock and fire hazard, use only the fuse specified in the parts list which is identical in respect to type, voltage rating, and current rating.**

## Connection to Power Source

The power input plug must be inserted only into a mating receptacle with a ground contact. Do not bypass the grounding connection. Any interruption of the grounding connection can create an electric shock hazard. Make sure that the receptacle is properly wired before inserting the plug.

Connect the transmitter to a ground outlet using supplied AC power cord.

The BGFT test instruments operate from a single-phase power source. The three-wire power cord requires a two-pole, three-terminal, live, neutral, and ground type connector.

Before connecting to the ac power source, determine that the instrument rating matches the voltage of the power source and has a suitable two-pole, three-terminal grounding type connector.

## ***Fuse Replacement***

Refer fuse replacement to qualified personnel only. To prevent electric shock and fire hazard, use only the fuse specified. See *Section 7 - Specifications & Replaceable Parts*.



**WARNING**

**No user serviceable parts inside! Refer all servicing to the factory or a qualified authorized service company!**



**CAUTION**

**Use only factory supplied mains cord! Mains cord shall not be substituted!**

Megger

# 3

## CONTROLS, INDICATORS AND CONNECTORS

### *Overview*

This chapter explains the locations and functions of the controls and indicators for the Dual Range BGFT **transmitter** and **receiver**. The first section covers the Dual Range BGFT **transmitter** and second covers the **receiver**.

Transmitter

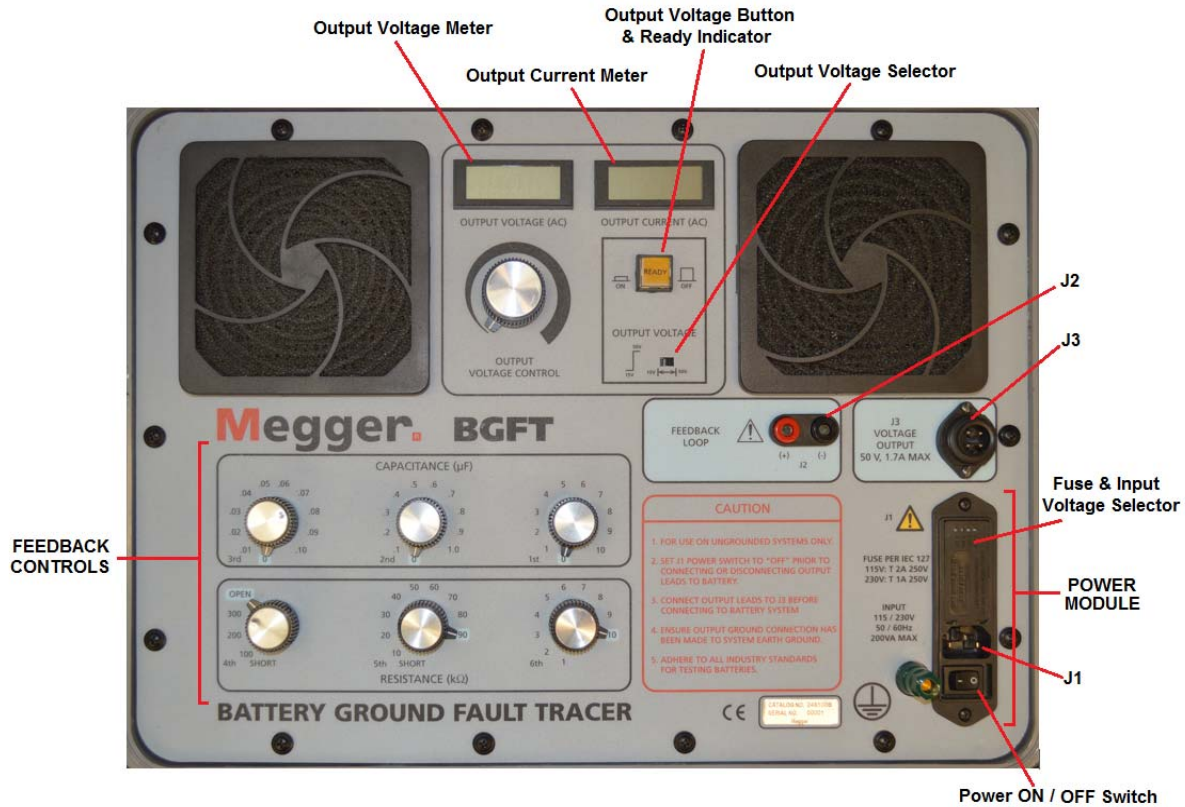

Figure 2: Transmitter Control Panel

**J1 receptacle** — 115 VAC, 50/60 Hz or 230 VAC 50/60 Hz receptacles for ac power. Power on/off switch controls power entry.

The switch is electrically connected to two fuses rated 2A Time Delay at 250 VAC or two fuses rated 1A Time Delay at 250 VAC. Over-current due to an internal fault condition removes ac power to the power supplies.

Refer to *Section 6, Maintenance and Repair*, for fuse replacement instructions. Use standard three wire line cord supplied with this instrument.



**WARNING**

Under no circumstances should the third wire ground (green/yellow wire) connection to the ac power line be disconnected or its continuity altered in any way.

**VOLTAGE SELECTOR** — The voltage selector configures the input of the unit to either 115VAC or 230VAC. The 115 VAC setting will operate on voltages from 103.5 VAC to 126.5 VAC. The 230 VAC setting will operate on voltages from 207 VAC to 253 VAC

The BGFT catalog number 246100C is set to 115 VAC at the factory.

The BGFT catalog number 246100C-47 is set to 230 VAC at the factory.

To alter the settings see *Section 6 - Maintenance and Repair*.

**NOTE:** *If the voltage selector setting is changed in the field then the internal fuses MUST be replaced as well.*

**F1 - FUSES** — The BGFT catalog number 246100C (115 VAC model) has 2A fuses installed at the factory. Only use factory recommended fuses. For Fuse type, see *Section 7 - Specifications and Replaceable Parts*.

The BGFT catalog number 246100C-47 (230 VAC model) has 1A fuses installed at the factory. Only use factory recommended fuses. For Fuse type, see *Section 7 - Specifications and Replaceable Parts*.

**J2 FEEDBACK** — dual banana jack colored red and black receives connections from the feedback cable supplied. The dual banana plug end of the lead should match up with the dual banana jack receptacle.

**J3 VOLTAGE OUTPUT jack** — receptacle for the current source leads. Insert by lining up the keyway with the receptacle slot and push in and turn to the right.



### WARNING

**The wiring for this connector is specific. A hazard to personnel and equipment could result if the connections to either end of this connector are compromised.**

**OUTPUT VOLTAGE meter** — Three-digit LCD shows representative terminal voltage at J3. This voltage is controlled by the VOLTAGE CONTROL dial mounted directly below the meter. Turning the VOLTAGE CONTROL clockwise increases output voltage.

**OUTPUT CURRENT meter** — Three-digit LCD indicates any current in excess of 10 mA produced by the transmitter. This includes the feedback current as well as the fault current.

**OUTPUT VOLTAGE SELECTOR** – Allows the operator to limit the output voltage to 15VAC open circuit, in the low range mode. This is an added safety feature to ensure that most miss-operations of the unit will not result in system faults. The output range can also be set to 50VAC open circuit in the high range mode. This will allow the unit to use its full range of power to locate high impedance faults; such as those caused by water ingress. It is recommended that all tests start on the low range.

**OUTPUT VOLTAGE / READY / CONNECT/DISCONNECT** switch – This illuminating switch, situated below the OUTPUT CURRENT meter, illuminates with an amber light when the transmitter has completed charging of the DC blocking capacitors located on the output and feedback circuits. The output can now be enabled by pressing the switch to its IN position or disabled by pressing the switch to its OUT position.

**FEEDBACK CONTROL** switches (manual bridges) – Six switches, three CAPACITANCE and three RESISTANCE, control the bridge mechanism. Turning clockwise increases the respective component value.

## Receiver

Figure 3 shows the receiver case.

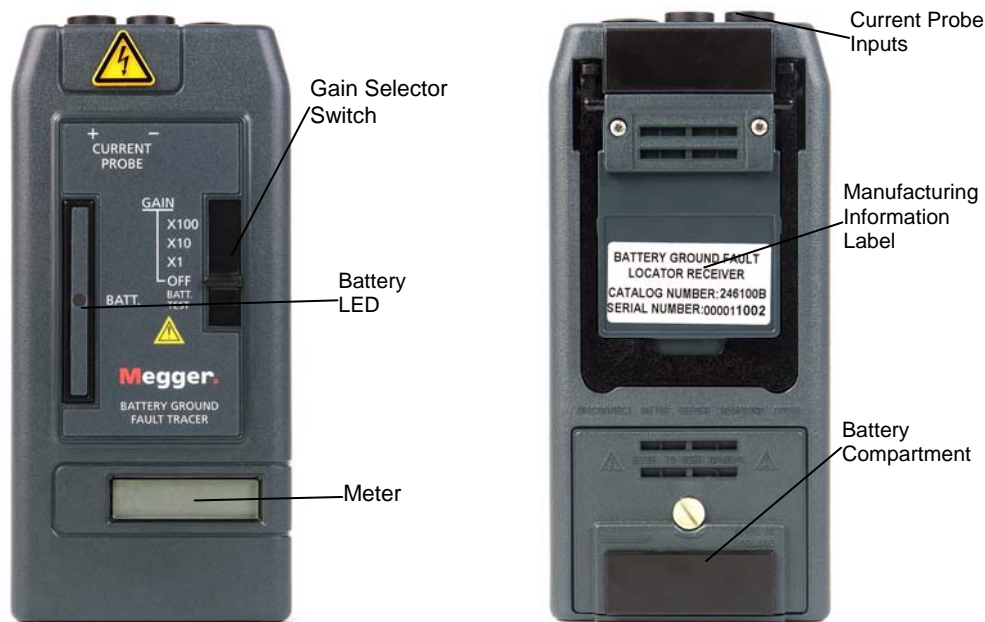

Figure 3: Receiver Case (Front/Back)

**GAIN selector switch** — Four-position lateral switch for selecting power on, 1, X10, and X100 gain. There is also an OFF position and a latched BAT. TEST position which tests internal 9 V battery supply voltage.

**BAT. LED** — This green LED indicates an adequate internal 9 V battery voltage. This LED lights when the selector switch is depressed fully to the BAT. TEST position.

**CURRENT PROBE inputs** — Two banana jacks are provided. These should correspond to the mating plugs of the current sensor.

**Meter** — Three and one-half digit display shows the magnitude of signal current sensed by the current probe and amplified by the selected gain.

**Battery compartment** — Situated on the reverse side of the receiver, access to the battery can be made by turning the slotted screw counterclockwise until loose.

**Manufacturing information label** — Contains catalog number and serial number.

### ***Current Probe***

**Current probe jaw opening control** — Press the handle extensions together until the opening is sufficient to encompass the cable under test.

**Direction arrow** — Since the probe aids in locating fault direction, the consistent orientation of the probe needs to be maintained by observing the red marking.

Megger

# 4

## OPERATION

### *General*

Once a ground fault condition is revealed either through monitoring equipment or inspection, the Dual Range Battery Ground Fault Tracer can be used to identify, track, and locate the fault or faults in the DC distribution system. The Dual Range Battery Ground Fault Tracer should be positioned at the highest level of distribution known to be fault free. Obviously, the farther away from the fault the unit is located, the longer it takes to locate. The distributed capacitance of cabling masks the resistive portion of the fault as distance is increased.

Once a distribution cabinet is selected, locate the nearest appropriate AC outlet and position the transmitter within the maximum AC line cord length supplied with the unit. As previously mentioned, only a grounded three-wire AC line cord should be connected to the transmitter and the ground wire should not be interrupted by extension cords or adapters. Refer to *Section 2 - Safety*, before connecting and operating the Dual Range Battery Ground Fault Tracer.

### **Transmitter Connections**

The Dual Range Battery Ground Fault Tracer can be used while the distribution system is in full operation. If safety regulations require otherwise, follow all operating and maintenance procedures specified at your facility.

1. Remove sufficient cabinet network to expose the DC supply bus and feeder connections. Identify the ground bus and the various supply bus connections. Some DC distribution systems have taps on their battery to supply two voltage systems. Common labeling is "P" for the most positive battery terminal; "PN" to identify the tap connection; and "N" to identify the most negative terminal. Other identifiers such as "A" system and "B" system are also used. Consult distribution schematics before connecting to the system if there is any question or if labeling is not clear.
2. Connect one side of the ground lead to the ground connection on the BGFT. Connect the clip side of the ground cable to earth ground.
3. Once the cabling for feeders and the DC bus is exposed, locate the source leads in the accessories bag. This two-wire cable can be identified by the four-pin connector at one end

and two alligator clip type connectors at the other end. The connectors on the clip end are distinguished from each other by their labels, which denote where the clips should be connected.



### WARNING

The source lead with the “Connect to Earth Ground” label should be attached only to the ground bus bar or frame ground.



### CAUTION

The source lead with the “Connect to Faulted Side of String” Label should be attached only to the battery bus connections. Inadvertent connection of the red source lead to the ground bus bar or frame could result in equipment damage.

4. Attach the source lead connector to J3 of the transmitter by inserting with the key positioned and turning the locking collar clockwise until snug.
5. Attach the source leads between the system ground and the faulted side of the battery string, per the labeling on the connectors.
6. Ensure that the power switch marked **0** (off) and **I** (on) is set to 0. Insert the female end of the AC line cord into the power receptacle located in the lower left corner of the transmitter and marked J1. Insert the male end into the appropriate AC outlet.

All connectors for the transmitter front panel should now be connected with a cable. Proceed to the next step, "Applying Transmitter Power."

## Configuring the BGFT

Before applying power, check all connections, set the following controls as specified, and adhere to all cautions listed on the upper-right portion of the transmitter control panel and those outlined in this manual.

1. Set VOLTAGE CONTROL fully counterclockwise to MIN.
2. Set the OUTPUT VOLTAGE switch to the OUT position.
3. Set the OUTPUT VOLTAGE range to 15V.
4. Set the RESISTANCE selector switches fully clockwise with the left-most switch set to OPEN (blue numbers)..

- Set the power switch at J1 to | (on). After a delay of approximately 30 seconds, the amber READY light should light, indicating that the transmitter is ready for operation.

The receiver is a battery-powered device, activated by moving the slide switch from the OFF position in an upward direction and selecting a gain position. Depending on signal strength, which is inversely proportional to the fault impedance, the necessity for increased gain will be a choice of receiver display resolution.

- Connect the two parts of the receiver, the clamp-on current probe that surrounds the cable to be examined and the display and metering unit, by placing the clamp-on wiring terminations (banana plugs) into the top part of the receiver at the mating banana jack connectors.

Disconnect the ground lead of any battery ground fault monitor or isolate it from the circuit if possible. (Battery ground fault monitors can add a path to ground).

## Applying Transmitter Test Voltage

**NOTE:** The amount of test voltage required will greatly depend upon the magnitude of fault impedance to be located and the system requirements for injected signals onto the distribution bus. The larger the signal applied, the more current will be available to the fault impedance and the more resolution capability the receiver will exhibit.

- Determine if the ground fault is on negative or positive side of the battery string by finding which side measures the lower voltage.
- If the ground fault is on the positive side of the string then connect the BGFT output transmitter cable between the positive battery terminal and earth ground.
- If the ground fault is on the negative side of the string then connect the BGFT output transmitter cable between the negative battery terminal and earth ground.
- Set the receiver to (x1) and place the receiver CT around the red transmitter lead of the BGFT. As shown in Figure 4.

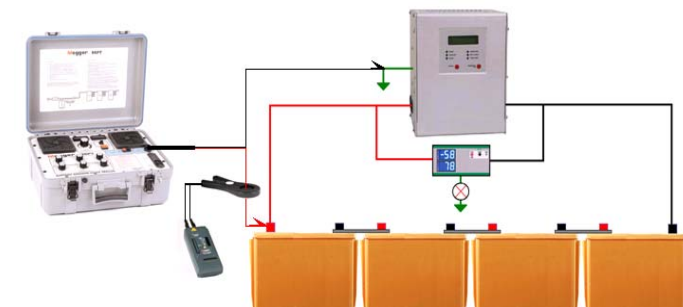

Figure 4: Test Connections

## Receiver Connections and Applying Power

**NOTE:** Do NOT connect the transmitter across the plus and minus terminals of the battery string.

Turn on the output of the BGFT by setting the output voltage push button on the transmitter to the IN position (CONNECTED).

Slowly raise the transmitter's output voltage, by turning the transmitter output control knob in a clockwise position. Slowly raise the voltage until the receiver measures current. (0.1 is sufficient).

If the receiver does not measure current then increase the scale to (X10) then (X100) if needed. (0.1 is still sufficient on either range).

Open the main panel and place the receiver clamp around each circuit individually.

Locate the circuit with the current flow. This will be the circuit with the ground fault.

If 2 or more circuits display the current then use the bridge in the unit to tune out any false paths (see Bridge Operation).

## Defining The Fault

The contributing impedance to ground can be defined by using the feedback cable and the bridge section of the transmitter. During the search for the fault, the initial connection is usually made at an upstream cabinet and may be some distance from the actual fault location.

This distance to the fault involves much wiring and many switch mechanisms. The distributive capacitance of this cable and switch mechanism may mask the true fault path with a high capacitance to ground. This capacitance at 20 Hz could present a low impedance to ground and prompt a search on the wrong feeder cable (phantom fault).

To help eliminate false impedance to ground, a feedback cable coupled to a decade bridge that defines the true impedance and allows a true resistance value of the fault to be recognized. This is accomplished by looping the feedback cable through the clamp-on current probe and thereby canceling the effect of resistance and capacitance on the measured injected fault current.

**NOTE:** Very high impedances exhibit low resolution readings on the receiver. To obtain better resolution, wrap an additional turn around the clamp-on jaws of the current probe thereby doubling the fault current. Remember to divide the bridge capacitance by the number of turns and to multiply the bridge resistance by the number of turns to identify the fault impedance.

## Bridge Operation

### Capacitance

With the FEEDBACK CONTROL switches set to the blue numbers as described in the paragraph on "*Transmitter Connections*," start with the capacitance section of the bridge. Observe the receiver display and dial in a capacitance from the bridge section. If the feedback cable is properly aligned, the displayed reading should start to decrease or remain the same.

If the displayed value starts to increase, then the feedback cable is entering the current probe from the wrong direction. Either reverse direction at the transmitter panel or change the orientation of the cable at the current probe.

If the displayed value remains the same, then the fault impedance is resistive in content and no further capacitance nulling is required. However, it is common for the displayed value on the receiver unit to reflect some capacitive effect. This is caused by the capacitance to ground in the feeder cable being investigated. Continue to dial in the capacitance values until either the displayed value reverses direction or the meter reaches minimum. If there are multiple turns of the feedback cable around the current probe, multiply the null balance capacitance displayed on the transmitter dials by the number of turns.

When the travel of the displayed value reverses direction, then the feedback capacitance is contributing to rather than canceling the capacitive impedance effect. Adjust to a minimum and proceed to the resistive balance. If the displayed value reaches zero or some minimal value and increasing the gain of the receiver does not provide any more resolution, then the path chosen contains no resistive path to ground measurable to the specifications of this device. Resistances at this point will be close to 1 M $\Omega$ .

### Resistance

After the feeder cable capacitance has been determined and no further addition of feedback capacitance reduces the displayed value, and may even start to increase the value, then the remaining fault impedance can be identified using the resistive portion of the bridge and feedback circuitry.

Move the left-most or highest value switch to the OPEN position and decrease the resistance selected until the displayed value reaches a null condition. Increasing the gain selector on the receiver provides resolution when required. Use the marked resistance dials to determine a value of fault resistance measured to ground. If there are multiple turns of the feedback cable around the current probe, divide the null balance resistance displayed on the transmitter dials by the number of turns.

## ***Tracing The Fault***

Once the fault impedance is defined and a suspected downstream path is determined, tracing the fault can begin. Trace the fault by moving the receiver downstream. If it becomes necessary to move the transmitter, then follow the procedure below.

Continue tracing faults by:

1. Shutting down the transmitter by following the Instrument Shutdown Procedure below.
2. Move the transmitter to the next location and reconnect to the buss.
3. Follow the Bridge Operation procedure in the previous section to locate the resistive faults. Keep the polarity of the current probe correct, at all times. When the displayed value decreases or reverses polarity, the location of the fault has been passed.
4. Repeat Steps 1 through 3 until all faults are located in the DC system.

## ***Instrument Shutdown Procedure***

It is important to the safety of the operator and to the future operation of the Dual Range Battery Ground Fault Tracer that an orderly shutdown and removal from the DC bus under test be accomplished.

1. Turn the VOLTAGE CONTROL fully counterclockwise.
2. Set the OUTPUT VOLTAGE switch to the OUT position (DISCONNECTED).
3. Set the ac power switch to 0 (off).
4. Remove the clamp-on device and the feedback cable from the receiver and transmitter cases, respectively.
5. Remove the red source lead first and then the black source lead from the DC bus under test.
6. Disconnect the ac power cord from the system source.
7. Disconnect the ground lead from earth ground then from the BGFT transmitter.
8. Carefully replace all components in the accessory bag and secure the transmitter case.

# 5

## APPLICATION NOTES

### *Shortcuts*

The following shortcuts can be used to save time when locating grounds:

1. A typical utility environment will have four main DC panels represented by one ground recorder. If physically possible, check the main cables or bus work feeding each cabinet (negative and positive) for the injected signal.
2. If a large imbalance of injected signal is observed with the receiver, start with the cabinet containing the largest signal level. The feedback circuit can be used, but remember that the resistance found is a total of all feeder resistances in parallel.
3. If a main feeder cable having ground current is detected and the cable is traced to a cabinet with many jumpers, divide and conquer. Move the receiver at a distance halfway from the last measurement point until the fault current disappears and reverse direction until the fault is located.
4. It is not necessary to move the transmitter every time you relocate to another cabinet during tracing. Moving is only necessary if the signal splits and the validity of the signal (resistive or capacitive current) requires the feedback circuit.
5. Remember to disable the ground monitor test resistor to ground before tracing a suspected fault. The low impedance of this test resistor may mask the parallel fault impedance.

### Example of Test

Power generating station XYZ requires assistance in locating a DC negative ground on its 120 V control battery bus. The Dual Range Battery Ground Fault Tracer is made ready in accordance with the instruction manual, making sure that the black lead is connected to the ground bus or suitable grounded point. Power system regulations limit bus perturbations to 10 V rms, so the transmitter output signal amplitude is pre-adjusted to that level. A data sheet is used to record the results and to help determine a pattern of search along with sufficient system one-line diagrams. The main distribution panels marked 10 AJ and 20 AJ are checked for signal strength (Fig. 5). There is no large difference between the negative and positive bus so a decision to start at panel 10 AJ is made.

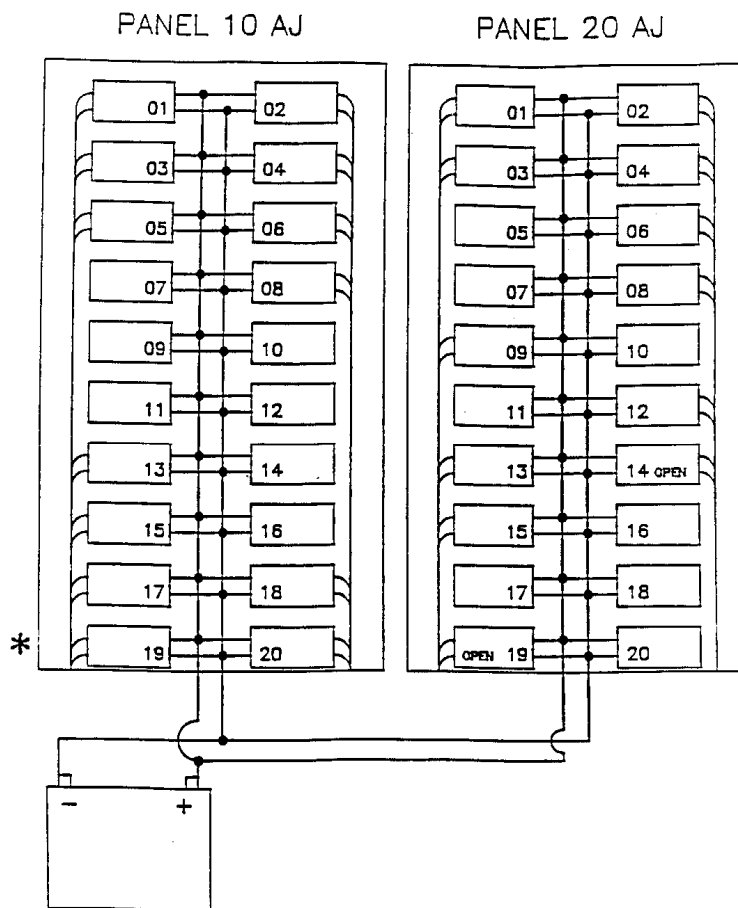

Figure 5: On-Line Diagram of Example

All feeder cables are checked (10 AJ 01-20) with the largest signal strengths on circuits 6, 11, and 19. Using the feedback circuit, circuits 6 and 11, impedances are determined to be capacitive in nature. However, circuit 19 presents a 5 k $\Omega$  resistance in addition to capacitive reactance on the balance bridge. A check of panel 20 AJ produces no significant signal levels when checked with the receiver. The negative bus ground alarm coincides with the significant ground located in panel 10 AJ. A starting point is determined and station prints indicate that circuit 19 feeds distribution panel 31 AB.

Panel 31 AB is located in another room and the decision is made to leave the transmitter connected as is to the main bus and use the receiver to track the signal. A reading is recorded with the feedback circuitry removed and the receiver is moved to panel 31 AB (Fig. 5).

At panel 31 AB, the main cable 1SY016 repeats the reading on its negative lead that was last taken at panel 10 AJ. With the receiver gain at X10 and the preset signal amplitude the same as before, the display indicates 0.200. The panel contains six circuit breakers and the signal is traced to the negative lead of cable 1ST405. Prints indicate that the cable enters cabinet 19 BAJ and connects to terminal block TB-MM-4. Furthermore, TB-MM-4 is jumpered to points 6, 8, 10, 12, 14, 16, 18, 20, 22, 24, 26, 28 (Fig. 6).

To conserve time and energy, a reading at the entry point, terminal 4 and a midpoint in the jumper string is selected. Terminal 4 signal level is 0.200; however, jumper 16 to 18 halves the signal to 0.100. Then proceed back through jumpers 6, 8, 10, 12 and 14 and determine signal strength at their outputs. Signal levels are 0.060 and 0.040 at terminals 8 and 14, respectively.

Since capacitance was present on the line during initial measurements at main panel 10 AJ, there is a good possibility that this split in signal may be capacitive in nature. To determine the true resistance path, the transmitter must be relocated to this panel and the feedback circuitry used.

The output of the transmitter is connected to point 4 of terminal block TB-MM and the black lead to an appropriate ground point. The output wires of the remaining terminal output points are checked with the bridge and the only resistive circuit to ground is discovered on terminal output point number 26.

Prints indicate that point 26 feeds into field cable 101 and proceeds to the transformer yard (Fig. 7). Leaving the transmitter connected as is, the receiver minus the feedback lead is moved to the transformer in the yard. Checking cable 101, we find no signal is present. This indicates that the ground lies between the cable 101 transformer connection and point 26 on TB-MM.

This is verified by obtaining permission to lift this circuit and seeing the ground alarm return to normal. All equipment is de-energized and packed up for future use.

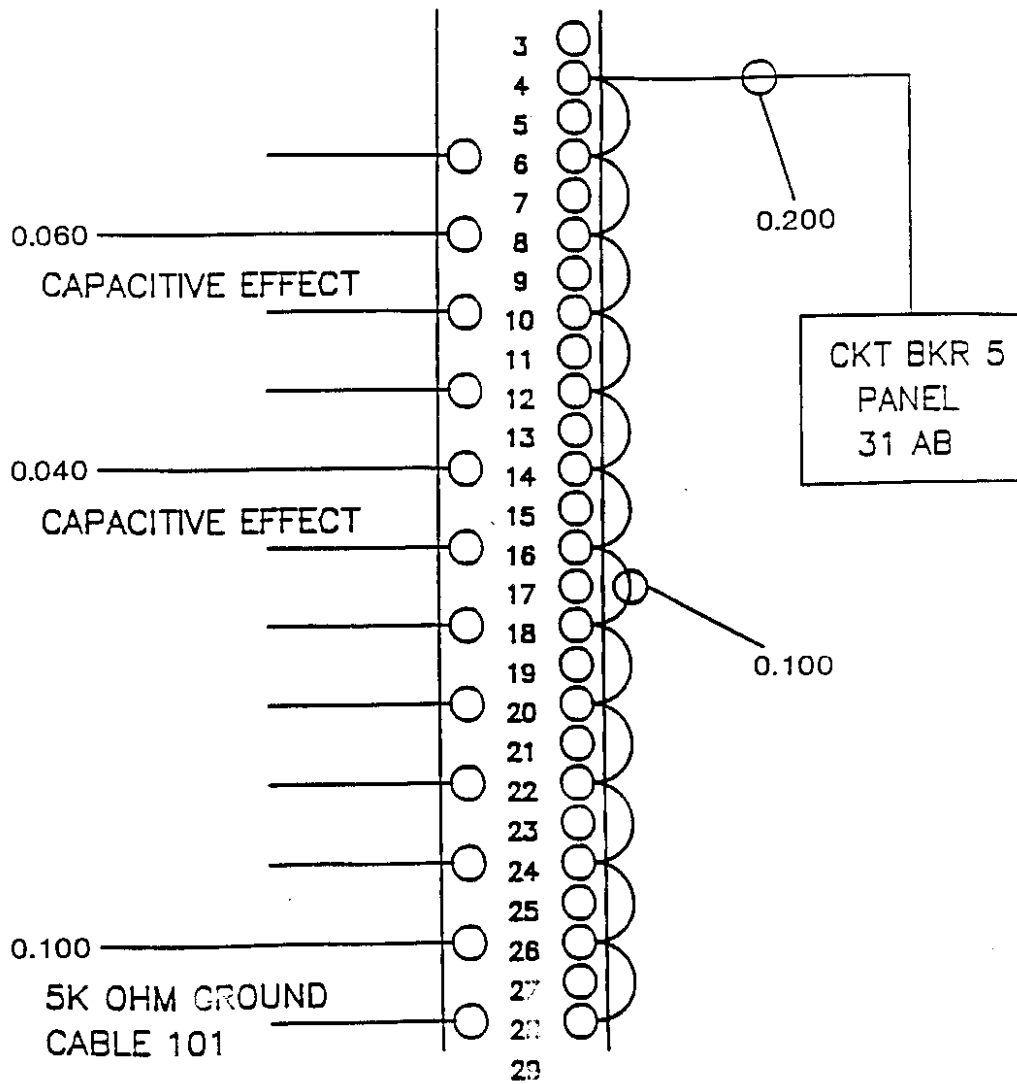

Figure 6: Panel 31 AB

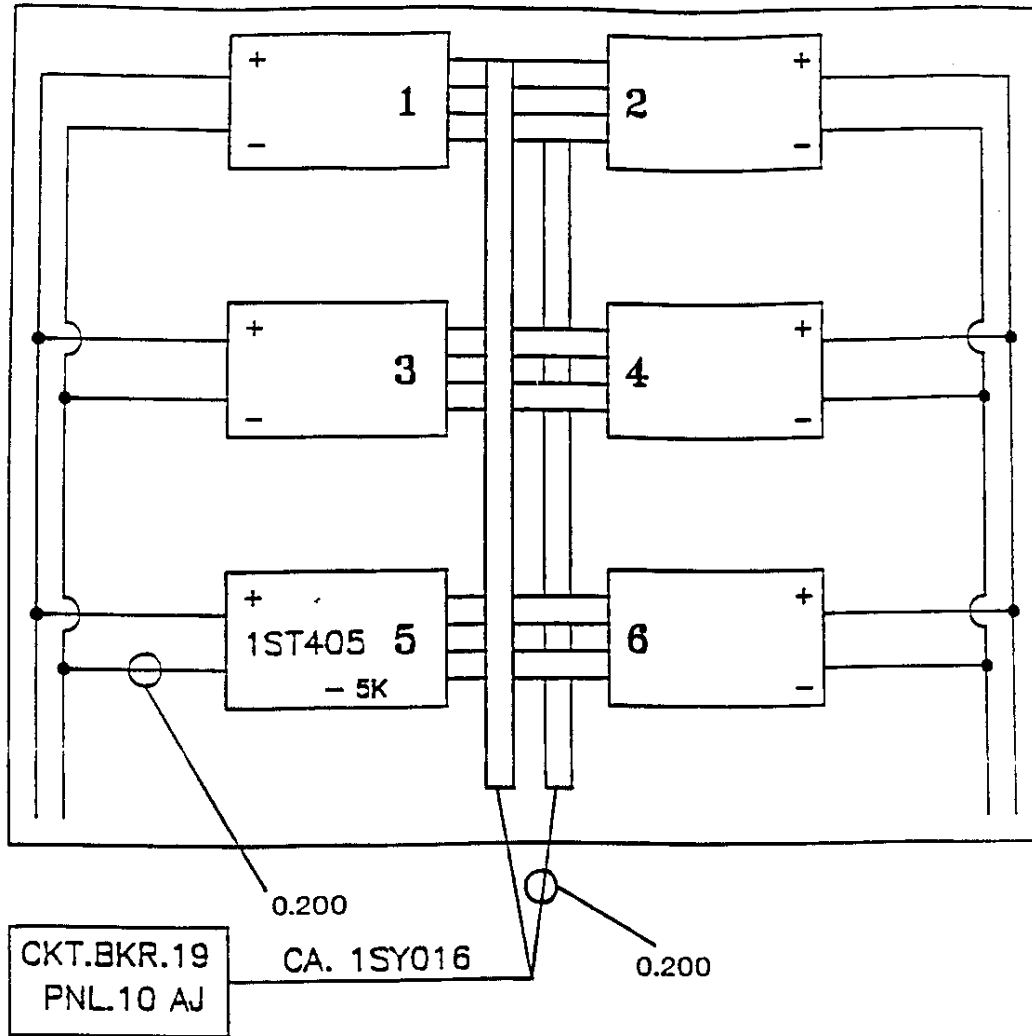

Figure 7: Terminal Block MM

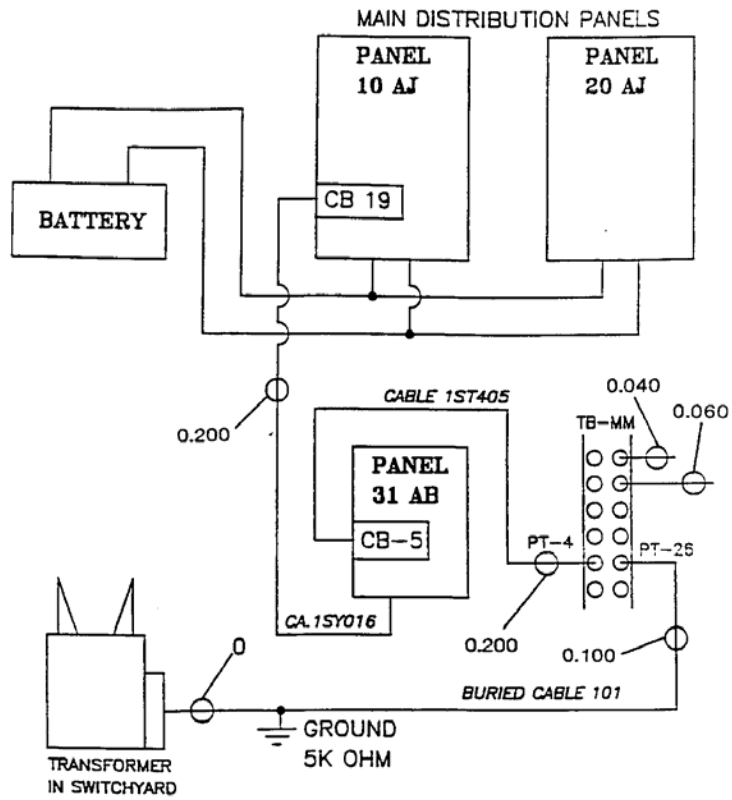

Figure 8: Main Distribution Panels

# 6

## MAINTENANCE & REPAIR

### *Maintenance*

Since the instrument and its components may be used in dirty and corrosive environments, periodically clean all components and test leads with a mild detergent and a soft cloth. Do not immerse the transmitter or receiver in water or allow moisture to enter the cases. Maintenance should only be carried out by qualified personnel.

Periodically (every six months) inspect and clean the case, as previously described, all test leads, and connections. Inspect the current probe leads and transmitter source leads for effects of corrosion and wear.

The power on/off switch on the transmitter panel contains a line fuse to protect the instrument from current overloads. These primary side fuses are rated for 2A Time Delay at 250 VAC or 1A Time Delay at 250 VAC. A line output fuse rated at 2 A ac 600 VAC is located inside the instrument.

The current output leads have a set of fuses, ATM-2 to protect the operator. These are fast acting, with high interrupting capacity. These fuses are designed to protect the user from catastrophic component failure.



#### **WARNING**

**Under no circumstances should these fuses be defeated or replaced with another type fuse. Replace with the type specified in *Section 7 Specifications & Replaceable Parts*.**

## DC fuse Test and Replacement

To verify that the problem is DC fuse related, move the instrument from the DC distribution system under test by de-energizing the equipment and detaching the source leads. With the transmitter source leads connected to J3, short the two clip ends together, turn the VOLTAGE CONTROL fully counterclockwise and apply power to the transmitter. Verify that the ac power remains on and that after the time delay, the amber READY lamp lights. Observe the ac OUTPUT CURRENT meter on the transmitter panel, and set the OUTPUT VOLTAGE switch to CONNECT. Turn the VOLTAGE CONTROL clockwise until the displayed current value increases from zero. If there is no output, then the DC fuse is likely damaged or a break has occurred in the test leads circuit.

If suitably trained personnel are available and fuse replacement is required, follow this procedure for fuse replacement.

1. Turn the VOLTAGE CONTROL fully counter-clockwise.
2. Set the OUTPUT VOLTAGE switch to DISCONNECT.
3. Remove all ac power to the transmitter by setting the power on/off switch to 0. Disconnect the AC line cord. Set the OUTPUT VOLTAGE switch to DISCONNECT.
4. If the current source leads are still connected, remove from the DC distribution bus under test.
5. Remove the source leads from their J3 connection on the transmitter front panel.
6. Disconnect the ground lead from earth ground then from the BGFT transmitter.



### WARNING

**This instrument contains several large capacitors. During operation some or all of these capacitors could become charged up to the capacity of the DC bus under test.**

**Normally these capacitors are automatically discharged when the leads are disconnected and the switches are set to the positions as described in steps 1 through 3.**

**However, under certain fault conditions, these capacitors may be left charged. Always use a voltmeter to check the state of the charge and wear rubber gloves as necessary when touching the capacitors and the circuits connected to them.**

7. Remove 14 Phillips head screws from the transmitter panel and lift the chassis to the top of the instrument case. Remove the entire chassis and rest it on a clean flat surface.
8. Find the fuse located in a double fuse holder. Only one slot of the fuse holder is wired; the remaining slot houses the spare fuse.

9. Remove the damaged fuse and replace with the spare. Using an ohmmeter, verify that the fuse is indeed bad.
10. Visually inspect all components within the transmitter chassis assembly for damage. Since the fuse was installed and sized to protect under component fault situations, this may indeed be the case. If no damage is observed, proceed to the next step. If damage is observed, return the transmitter to the Megger Repair Department.
11. Replace the chassis in the instrument case, replace the 14 screws and test again as described above. If the instrument still does not respond correctly, return it to the Megger Repair Department.

## **Amplifier Output Fuse Test and Replacement**

The output amplifier section is configured in a push-pull arrangement that requires a measure of DC balance between each output transistor array. In the event of component failure or radical calibration drift, the outputs become unbalanced and one phase works harder than the other. This causes an imbalance in the current available and also causes the individual phase protection fuse to interrupt. Inadvertent connection to an ac bus could also cause one or both of the fuses to interrupt.

An indication of this problem is a reduction in current and voltage available to the output. Normal current available to shorted output source leads at maximum clockwise adjustment of the VOLTAGE CONTROL is approximately 0.5A ac **at a voltage of 15VAC** or 1.7 A ac at a voltage of 50 VAC rms. Neither of these values is attainable in the event of an amplifier output fuse interruption.

If both fuses interrupted, there would be no output indication whatsoever, and a symptom similar to an interrupted DC fuse would be evident.

1. Perform steps 1 through 4 of the procedure for replacement of the DC fuse.
2. Locate the FET DRIVER PRINTED CIRCUIT BOARD in the middle of the transmitter chassis assembly. The two amplifier output fuses are located directly beneath the heat sink and mounted to the printed circuit board in clip fuse holders.
3. Remove the damaged fuse and replace with a new one. Refer to *Section 7 - Specifications & Replaceable Parts*, for rating and size.

## AC line Fuse Test and Replacement

If the transmitter does not respond to the application of AC line voltage, check the fuses protecting the ac input circuitry. To check and/or replace these fuses, perform the following steps.

1. Perform steps 1 through 3 of the procedure for replacement of the DC fuse.
2. Using a small flat blade screwdriver, insert the tip into the slot located at the top of the ac power entrance module J1. The front face of the module will swing outward.
3. Remove the fuse cartridges located within the module and marked with an arrow pointing to the right of the transmitter.
4. Replace the fuses and restore the fuse cartridges to their previous location. Replace the line fuses with direct replacements as specified in *Section 7 - Specifications & Replaceable Parts*.
5. Close the front face cover of the ac entrance module and retest the transmitter. If the fuses continue to interrupt, it is recommended that the entire unit be sent to the Megger Repair Department.

## Changing voltage selector settings

1. To change the selected voltage: open the fuse cover using a small blade screw driver or similar tool. Pull the voltage selector card straight out of the housing, using the indicator pin. Orient the indicator pin ton point up when the desired voltage is legible at the bottom. Insert the voltage selector card into the housing with the printed side of the card facing forward toward the IEC connector and edge containing the desired voltage first. Replace cover and verify the indicator pin shows the desired voltage.

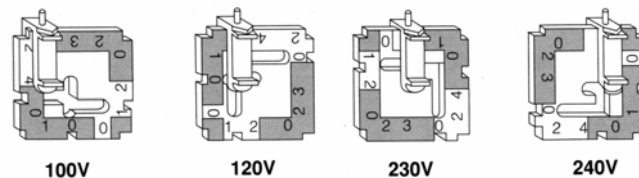

Figure 9: Voltage Selector Card Orientation

**NOTE:** When the voltage selector is set to either the 100V or 120V position the BGFT will be configured for 115VAC operation. For 115VAC operation the input module will require 2A fuses.

When the voltage selector is set to either the 230V or 240V position the BGFT will be configured for 230VAC operation. For 115VAC operation the input module will require 1A fuses.

## **Battery Replacement (Receiver)**

### **BATTERIES**

The crossed-out wheeled bin placed on the batteries is a reminder not to dispose of them with general waste at the end of their life.

This product contains a 9 V alkaline battery.

They are located in the BGFT receiver. (P/N 30001-1)

They can be safely removed by performing the following steps.

1. Remove the battery compartment cover by turning the slotted screw with a flat blade screwdriver counterclockwise until the cover separates from the case.
2. Remove the battery and disconnect the battery supply leads.
3. Replace with an adequate substitute battery (refer to *Section 7 - Specifications & Replaceable Parts*), reconnect the supply lead, and insert the battery into the case.
4. Replace the battery compartment cover and reinstall the screw being careful not to over-tighten or cross-thread the restraining screw.

Spent batteries are classified as Portable Batteries and should be disposed of in accordance with Local Authority requirements. Megger is registered in the UK as a producer of batteries.

The Registration number is BPRN01235

## ***Repair***

Megger offers complete repair service and recommends that its customers take advantage of this service in the event of equipment malfunction. Please call 610-676-8500 and ask for Customer Service to obtain an RA #, then ship to:

Megger  
ATTN: Repair Department  
Valley Forge Corporate Center  
2621 Van Buren Avenue  
Norristown, PA 19403 U.S.A.

TEL: 610-675-8500

It is best if you return the entire instrument, including leads, to help us find the source of the problem. Many times the problem appears to be the **transmitter**, but the problem is eventually found to be in the **receiver**. Please indicate all pertinent information, including problem symptoms and attempted repairs. Equipment returned for repair must be shipped prepaid and insured and marked for the attention of the Repair Department.

## ***Preparation for Storage and Shipment***

Remove the battery from the receiver before shipment or long-term storage. Storage temperature for the Battery Ground Fault Tracer should not exceed the range -5 to 130°F (-20 to 55°C). Pack in a carton or box (original shipping container if available) in accordance with best commercial practice. Seal container with waterproof tape.

# 7

## SPECIFICATIONS & REPLACEABLE PARTS

### *Specifications*

#### Environmental

<b>Operating temperature range:</b>	32 to 105°F (0 to 40°C)
<b>Storage temperature range:</b>	-5 to 130°F (-20 to 55°C)
<b>Humidity:</b>	20 to 95% RH non-condensing

#### Transmitter

##### **Mechanical**

<b>Dimensions:</b>	7.5 x 18.5 x 14.6 in. (H x W x D) (19 x 47 x 37 cm)
<b>Weight:</b>	35 lb (15.9 kg)

##### **Electrical**

<b>Maximum voltage to ground:</b>	250 VDC
<b>Mains:</b>	115 VAC $\pm 10\%$ for the 246100C @ 50/60 Hz, 200 VA max. 230 VAC $\pm 10\%$ for the 246100C-47 @ 50/60 Hz, 200 VA max.
<b>Source voltage:</b>	variable 0 to 15 V rms in low range variable 0 to 50 V rms in high range
<b>Source current:</b>	load dependent 0 to 1.7 A rms
<b>Source frequency:</b>	20 Hz $\pm 2\%$
<b>Display (volts):</b>	three-digit LCD $\pm 5\%$
<b>Display (current):</b>	three-digit LCD $\pm 5\%$
<b>Fuses:</b>	DC output, ATM2, 2 A, 600 VDC FET Driver, time-delay, 2 A, 250 V (internal) AC line, 5 x 20mm., 2A, 250 VAC, time delay

AC line, 5 x 20 mm, 1A, 250 VAC, time delay

## Operational

<b>Fault resistance:</b>	1 to 399 k $\Omega$ @ 50 V bridge accuracy $\pm 10\%$
<b>Line capacitance:</b>	0.01 to 11.1 $\mu\text{F}$ bridge accuracy $\pm 20\%$

## Receiver

<b>Electrical:</b>	9 V alkaline battery
<b>Power (max.):</b>	11 mA at 9 VDC
<b>Battery life:</b>	40 hours continuous use at 20°C (estimated)

## Standard Accessories

**Source leads:** Two single conductor, 14 AWG, 600 V insulation, each conductor fused at 2 A, 600 VDC

**Current probe**

**AC line cord**

**Feedback cable,** single conductor, 18 AWG, 600 V insulation

**Instruction Manual**

**Accessories bag**

**Ground Cable**

## ***Replaceable Parts List***

<b>Description</b>	<b>Part Number</b>
Accessories bag	29996
US style AC line cord	17032-7
EU style AC line cord	17032-13
UK style AC line cord	17032-12
Battery, 9 V alkaline	1482-1
Clamp-on current probe	29999-1
Feedback cable assembly	29998
Fuses, source lead, ATM 2 A, 600 VDC	29440-2
Fuses, FET Driver, time delay, 2 A, 250 V	2567-27
F1 AC line fuse, 5 x 20 mm 2A Time Delay, 250 VAC	27708-3
F1 AC line fuse, 5 x 20 mm 1A Time Delay, 250 VAC	27708-5
F2 DC fuse, ATM2, 2 A, 600 VDC	29440-2
Instruction manual	AVTM246100C
Receiver assembly	30001-1
Source lead assembly, 20 ft long, fused leads TYPE ATM, 2 A	29386-3
Ground Cable	1004-648

Megger